



X Performer Forming Taps

XPF SERIES

Volume 10



More than 60 new
sizes added



INDEX

Metric

A-XPF	PAGE 16
A-OIL-XPF NEW SIZE	PAGE 17
A-XPF 6GX NEW	PAGE 18
A-XPF 7GX NEW	PAGE 19
A-XPF FORM E NEW	PAGE 20
A-OIL-XPF FORM E NEW	PAGE 21
S-XPF	PAGE 22
S-OIL-XPF NEW SIZE	PAGE 23
S-XPF 6GX	PAGE 24
S-OIL-XPF 6GX	PAGE 25
S-XPF 7GX	PAGE 26
S-XPF+0.1	PAGE 27
S-XPF FORM D	PAGE 28
S-XPF FORM E	PAGE 29
S-OIL-XPF FORM E NEW SIZE	PAGE 30
S-LT-XPF	PAGE 31
S-OIL-LT-XPF	PAGE 32
S-XPF-LH	PAGE 33
S-XPF-HB Weldon	PAGE 34
S-XPF-GL	PAGE 35
S-XPF-GL 6GX	PAGE 36
C-OIL-XPF	PAGE 37

Metric Fine

A-XPF.....	PAGE 38
A-OIL-XPF NEW SIZES	PAGE 39
A-XPF 6GX NEW	PAGE 40
A-XPF FORM E NEW	PAGE 41
S-XPF.....	PAGE 42
S-OIL-XPF.....	PAGE 43
S-XPF 6GX.....	PAGE 44
S-OIL-XPF 6GX.....	PAGE 45
S-XPF FORM D.....	PAGE 46
S-XPF FORM E.....	PAGE 47
S-OIL-XPF FORM E.....	PAGE 48
S-OIL-LT-XPF.....	PAGE 49
S-XPF-GL.....	PAGE 50
S-XPF-GL 6GX.....	PAGE 51
C-OIL-XPF.....	PAGE 52
UNC	
S-XPF.....	PAGE 53
S-OIL-XPF.....	PAGE 54
UNF	
S-XPF.....	PAGE 55
S-OIL-XPF.....	PAGE 56
G (BSP)	
A-XPF NEW	PAGE 57
A-OIL-XPF NEW	PAGE 58
A-XPF FORM E NEW	PAGE 59
A-OIL-XPF FORM E NEW	PAGE 60
S-XPF.....	PAGE 61
S-OIL-XPF.....	PAGE 62
S-XPF-GL.....	PAGE 63

X PERFORMER FORMING (XPF) TAP SERIES

1 Low-torque spec with specially designed threading

2 V-Coating: extreme wear resistance

3 Size range from M1 to M45



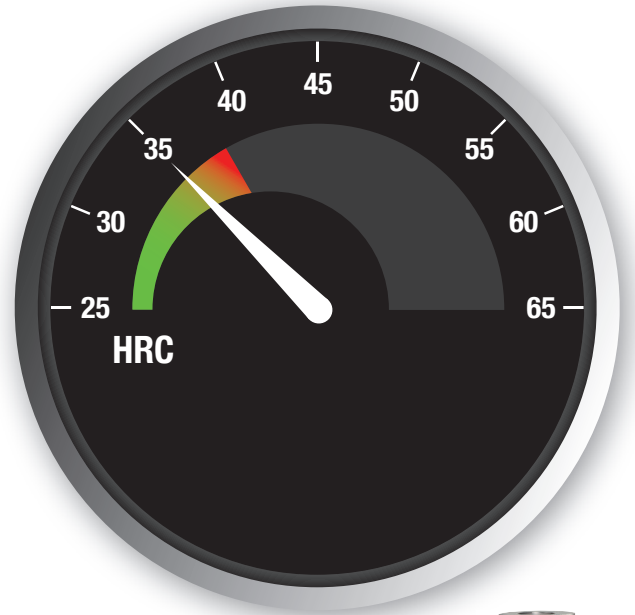
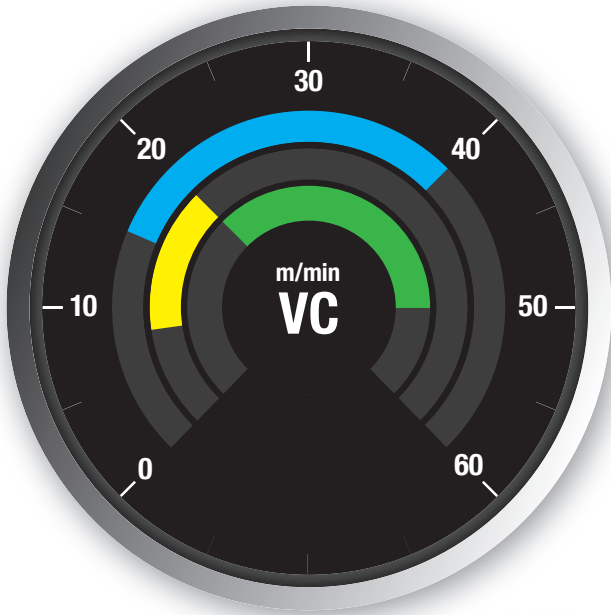
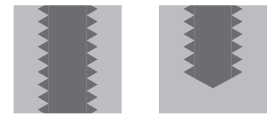
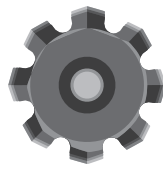

A-XPF Series

First choice in quality and performance

Powder metal forming tap for through & blind holes

Multilayer VI coating: extreme wear resistance

High speed tapping in general steels, aluminium, stainless steels



S-XPF Series

First choice in quality and performance

HSSE forming tap for through & blind holes

Multilayer V coating: extreme wear resistance

For general steels, stainless steels, aluminium



XPF IS DIFFERENT FROM OTHERS!



Reducing approx. **40%** of machining torque

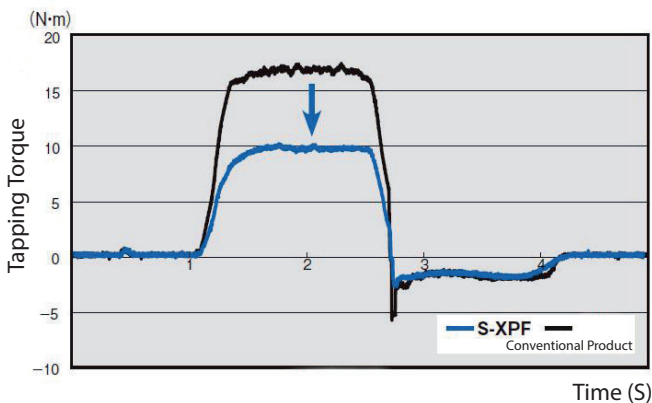

Restraining Burrs

Reducing approx. **20%** of heat generation

A thermograph image taken immediately after tapping

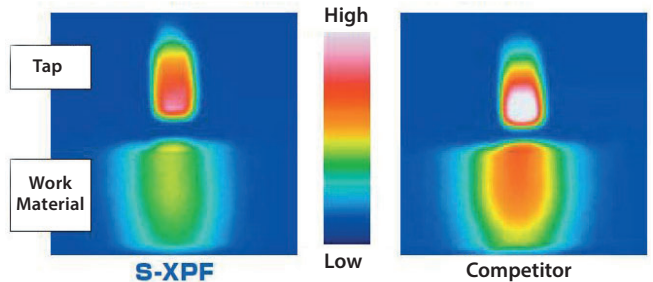

* To photograph the process, machining was carried out by applying paste instead of using coolant. However, during normal machining, coolant should be used.

Resistance improved

Minimum Quantity Lubrication

XPF has a high durability even machining with chlorine-free coolant. S-OIL-XPF is also suitable for MQL machining operation.



Deciding cutting speed

Does low cutting speed contribute to long tool life? It doesn't apply to XPF. Slow speed tapping, which generates less heat, causes bigger cutting resistance and tool wear. Cutting speed should be adjusted properly to find the most appropriate cutting speed for tool life.

Comparison of durability by the difference in cutting speed

Tool	S-OIL-XPF M8 x 1,25
Work Material	S50C
Hole Size	Ø 7,4 x 23 mm (Blind)
Tapping Length	18 mm (2,3D) (Blind)
Cutting Speed	10~40 m/min
Coolant	MQL 50cc/h (Internal)
Machine	Horizontal Machining Center

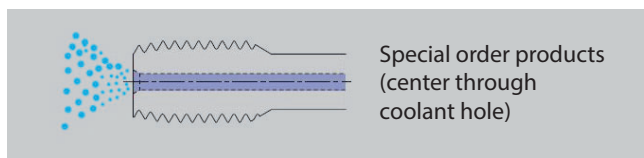

Cutting Speed	Tapping Holes					
	1.000	2.000	3.000	4.000	5.000	
10m/min	2.500 (Holes)					Excessive Wear
	3.000 (Holes)					Excessive Wear
20m/min	4.500 (Holes)					Excessive Wear
	4.375 (Holes)					GP-OUT
30m/min	3.806 (Holes)					Excessive Rubbing Noise
	3.355 (Holes)					GP-OUT
40m/min	1.606 (Holes)					GP-OUT
	812 (Holes)					GP-OUT

Choosing the Appropriate Coolant

High lubricant water-soluble coolant is highly recommended as well as non-soluble coolant. Water-soluble coolant must be used for high speed cutting. Non-soluble coolant can be used is only 20m/min or below.

Machining Holder and Work Holding

Please select the appropriate equipment depending on the maximum torque, torque curve, and others of the machine. XPF generates lower torque, as compared with the conventional forming taps.

Calculation for torque

XPF achieves 30% reduction of torque, according to the calculation. The tapping data on page 3 shows 40% reduction of torque in synergy with appropriate cutting speed. Please refer to the following table for large diameter tapping and the formula for calculating torque.

Calculated machining torque of large diameter taps by work materials

Thread Size	Pitch Diameter	Coefficient of Work Material					
		2	4	8	11	12	14
		AC	ADC	Bs	SS400	S45C	SCM (~35HRC)
M18 X 2,5	16,376	14	28	56	77	84	98
M18 X 1,5	17,026	5	11	21	29	32	37
M20 X 2,5	18,376	16	32	63	87	95	110
M20 X 1,5	19,026	6	12	24	32	35	41
M22 X 2,5	20,376	17	35	70	96	105	122
M22 X 1,5	21,026	6	13	26	36	39	45
M24 X 3,0	22,051	27	54	109	150	163	191
M24 X 1,5	23,026	7	14	28	39	43	50
M27 X 3,0	25,051	31	62	124	170	186	217
M30 X 3,5	27,727	47	93	187	256	280	326
M33 X 3,5	30,727	52	103	207	284	310	362
M36 X 4,0	33,402	73	147	293	404	440	514
M42 X 4,5	39,077	109	217	435	597	652	760
M45 X 4,5	42,077	117	234	468	643	702	819

* Please note that this shows the theoretical values of machining torques in case of the external supply of water-soluble coolant
 * It does not guarantee the actual torque.

Following formulas are used for calculating torque

Torque calculation for forming Tap

Conventional forming taps

$$T = 0,09806 \times K \times E \times P^2$$

T : Torque

K : Coefficient of work material

XPF series

$$T = 0,06864 \times K \times E \times P^2$$

E : Pitch diameter

P : Pitch

In case of M30 X 3,5 working on SCM440

$$T = 0,06864 \times 14 \times 27,727 \times 3,5^2 = 326 \text{ N/m}$$

The above formulas are the guideline in case of the external supply of water-soluble coolant. Please note that the actual torque changes depending on the work environment.

Work Material	Coefficient
Aluminium Alloy	2
Aluminium Die Casting	3~4
Brass	6~8
Mild Steel	10~11
Carbon Steel	11~12
Alloy Steel (Hardened Steel)	13~14

USEFUL TIPS

Countermeasure for burr

Comparing with the conventional forming taps, XPF reduces burr with low-torque spec.

Tool	S-XPF M3x0,5 4P	Conv. Forming Tap
Work Material	Brass	
Hole Size	Ø 2,76 x 3mm (Through)	
Tapping Length	3mm (Through)	
Cutting Speed	(N/A)	
Coolant	Non-Water Soluble	
Machine	Specialized Machine	

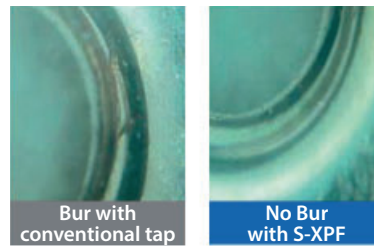
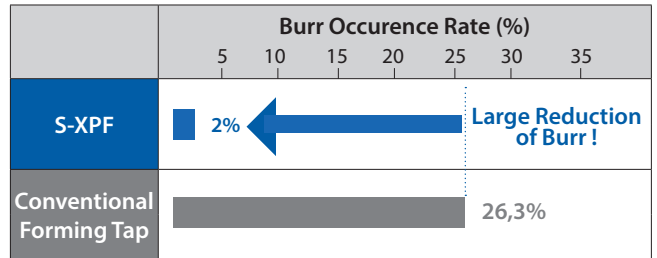

Recommending 60° for the chamfer

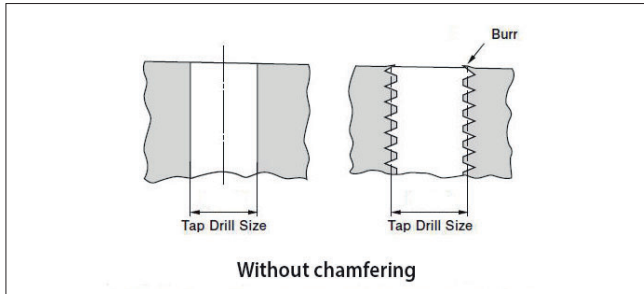

Forming tap forms the screw thread by plastic deformation. Therefore, without having chamfering, burr is made on the edge of the hole. To prevent burr, chamfering with 60° is highly recommended

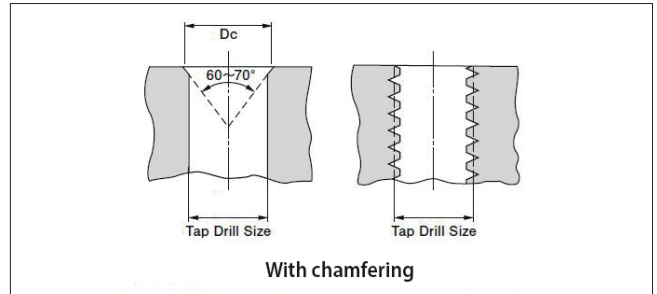

If 118° of chamfering is required for drilling, burr is prevented by setting the diameter of chamfering to screw size + 2 pitches (Example: M10x1,5 ⇒ 10mm (1,5x2)=13mm)

Shape of complete thread and it's difference

The formed thread has a small slit at the crest.

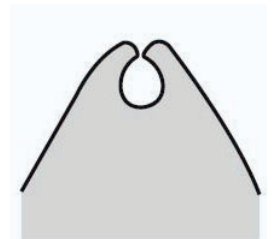
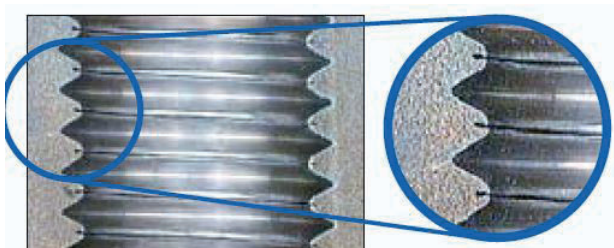

Forming taps are even 35HRC

Tool	S-XPf M6x1 4P
Work Material	SCM440 (35HRC)
Hole Size	Ø5,51~Ø5,52 x 16mm (Through)
Tapping Length	16mm (Through)
Cutting Speed	15m/min (796 min ⁻¹)
Coolant	Water Soluble Chlorine Free (External)
Machine	Horizontal Machine Center

	Tapping Holes			
	200	400	600	800
S-XPf	664 (Holes)			
	579 (Holes)			
Conventional Product	170 (Holes)			
	223 (Holes)			
Competitor Product	136 (Holes)			
	117 (Holes)			

Thread-rolling process of M45 is no longer a dream

Tool	S-XPf M45x4,5 2P
Work Material	SS400
Hole Size	Ø42,65~Ø42,68 x 45,5mm (Blind)
Tapping Length	36mm (0,8D) (Blind)
Cutting Speed	5m/min (133 min ⁻¹)
Coolant	Water Soluble Chlorine Free (External)
Machine	Horizontal Machine Center



Torque for above machining process is equivalent to 674N·M.
Water-soluble coolant and paste are also appropriate for this case.

Achieving high efficiency with MQL

Tool	S-OIL-XPf M12x1,75 2P	Conventional Forming Tap
Work Material	SCM420	
Hole Size	Ø11,1x45mm (Blind)	
Tapping Length	36mm (3D) (Blind)	
Cutting Speed	40m/min (1.062 min ⁻¹)	
Coolant	MQL (Internal)	Water Soluble Chlorine Free (External)
Machine	Horizontal Machine Center	

	Tapping Holes	
	5	10
S-OIL-XPf	8 (Holes)	Still Running
Conventional Forming Tap	0 (Hole)	

17 times the durability of cutting taps !

Tool	S-XPf M6x1 2P		Spiral fluted Tap M6x1
Work Material	S45C (90HRB)		
Hole Size	Ø5,55x25mm(Through)	Ø5x15mm(Through)	
Tapping Length	18mm (3D) (Blind)	12mm (2D) (Blind)	
Cutting Speed	15m/min (796 min ⁻¹)	10m/min (530 min ⁻¹)	
Coolant	Water Soluble Chlorine Free (10%)		
Machine	Horizontal Machine Center		

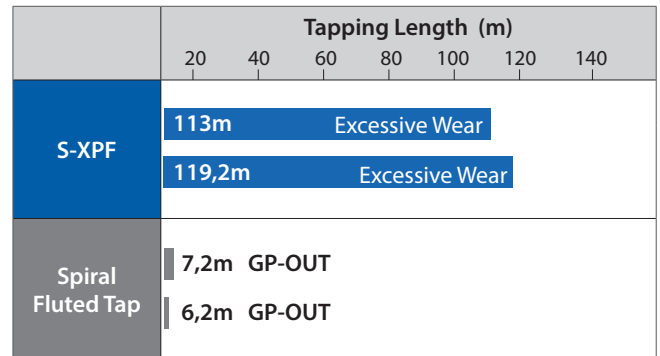

Ideal for work material especially for small diameter threads

Tool	S-XPf M1x0,25 2P			
Work Material	SCM440 Chrome Molybdenum Alloy	SUS420 (30HRC) Stainless Steel	SPCC Cold Rolled Steel	C2801P Brass
Hole Size	Ø0,89 ~ 0,90 x 4mm (Through)			
Tapping Length	2mm (2D) (Blind)			
Cutting Speed	5m/min (1.590 min ⁻¹)		10m/min (3.180 min ⁻¹)	
Coolant	Water Soluble Chlorine Free (10%)			
Machine	Vertical Machine Center			

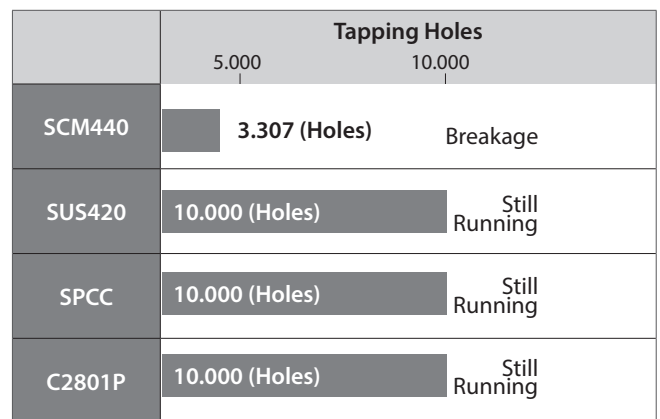

Internally-fed coolant improve tool life

Tool	S-OIL-XPf M10x1,5 2P	
Work Material	SCM440 (35HRC)	
Hole Size	Ø9,3x24mm (Through)	
Tapping Length	20mm (2D) (Blind)	
Cutting Speed	20m/min	
Coolant	Water Soluble Chlorine Free (5%)	
Machine	Horizontal Machine Center	

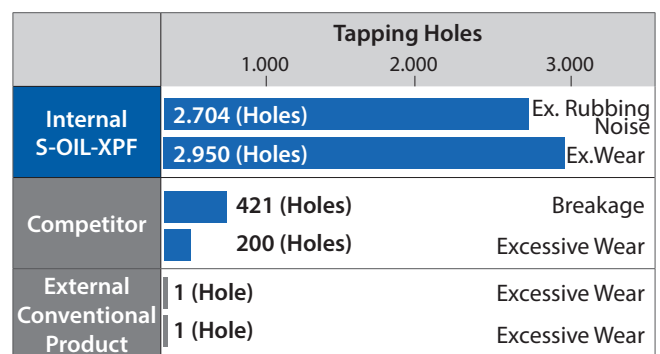

DO YOU HAVE ANY PROBLEMS WITH TAPPING?

Most tapping troubles are caused by unstable chip evacuation. The A-XPF forms threads by plastic deformation of the work material and does not generate cutting chips. It is a revolutionary product that excels in a wide range of work materials and cutting conditions.

Tapping Troubles		
No.1	Breakage and chipping	26%
No.2	Dimensional error	17%
No.3	Galling	14%
	Other	43%

Main factor is chip packing

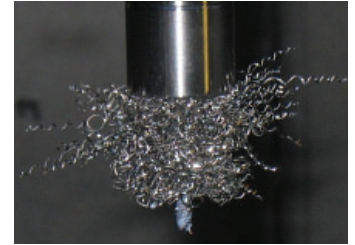

Source: OSG Technical Consultation Division

IMPROVES PRODUCTIVITY WITH ZERO CUTTING CHIPS

Stable machining with reduced thrust

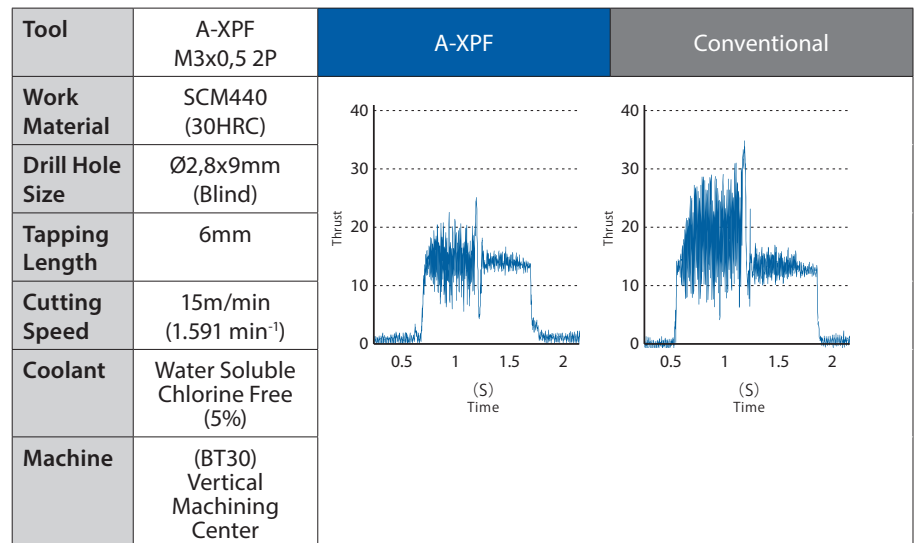

(PAT. in Japan)
Special chamfer specification
Achieves low thrust

(PAT. in Japan)
Special thread configuration
Improves thread rigidity

(PAT. in Japan)
VI coating dedicated to high-performance taps

Powder Metallurgy HSS(CPM)
High wear resistance

Improved machining efficiency and durability

■ Improved cutting edge rigidity by a special thread shape

■ VI Coating **NEW**

Coating with high-hardness, oxidation resistance, and excellent lubricity that is suitable for high-load machining

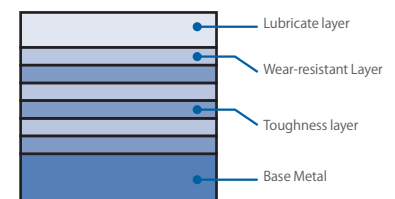

Coating Color	Coating Structure	(GPa) Hardness	(°C) Oxidation Temperature	Adhesion Strength	Surface Roughness	Wear Resistance	Welding Resistance	Toughness
Black	Cr-based composite multilayer film	45	1.100	◎	☆	◎	☆	◎

○→◎→☆
Fair Best

ENERGY CONSERVATION BY REDUCING MACHINE DOWNTIME

Reduction of tool change time caused by cutting chip troubles and machine downtime required for removing accumulated cutting chips.

By enabling stable and uninterrupted machining, power consumption can be reduced

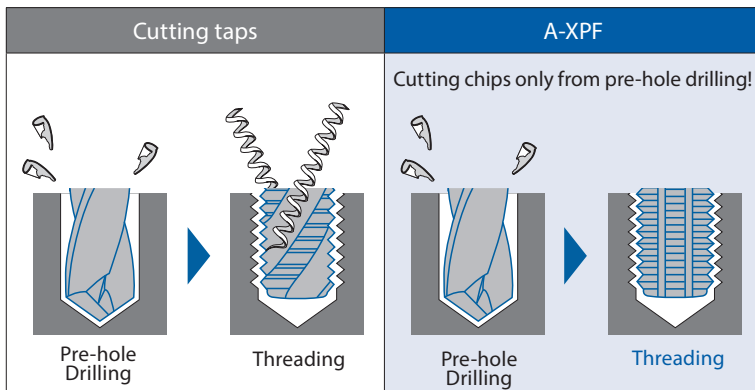

Forming taps do not generate cutting chips during threading, which reduces the overall amount of chip accumulation.

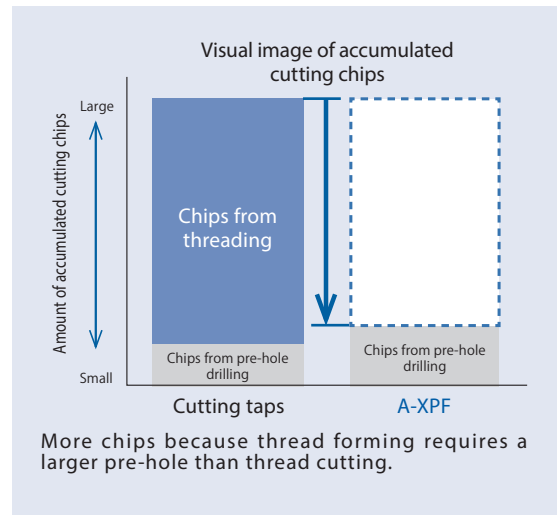

Small diameter threading

Achieves excellent durability in small-diameter machining by reducing thrust

Tool	A-XPF M1 x 0,25 2P
Work Material	SUS420J2(192HBW)
Drill Hole Size	Ø0,91x3.5mm (Blind)
Tapping Length	2mm
Cutting Speed	10m/min (3.183 min ⁻¹)
Coolant	Water Soluble Chlorine Free (5%)
Machine	Vertical Machining Center

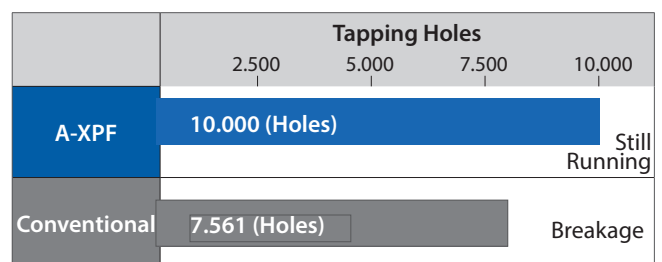

Outstanding durability even when machining small-diameter threads in martensitic stainless steel

Achieves cutting speed of 30m/min in high-hardness material

High-speed machining of high-hardness material with the synergistic effect of VI Coating™

Tool	A-XPF M6 x 1 2P
Work Material	SCM440 (30HRC)
Drill Hole Size	Ø5,52x19mm (Blind)
Tapping Length	12mm
Cutting Speed	30m/min (1.591 min ⁻¹)
Coolant	Water Soluble Chlorine Free (5%)
Machine	Horizontal Machining Center

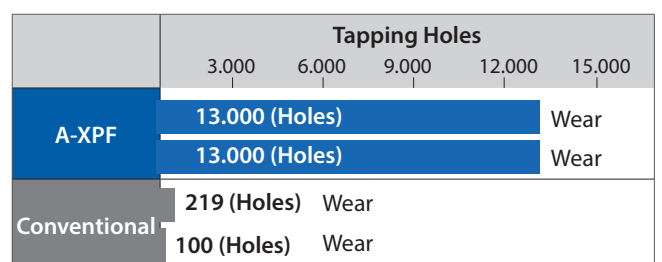

Achieves high-speed and stable machining in SCM440(30 HRC)

For testing purposes, the conventional product was also used under high-speed cutting condition.

CUTTING DATA

Suitable for small precision parts that are becoming thinner and lighter with little room for pre-hole

Short chamfer (length of chamfer: 1P)

Machining of high-hardness material

Tool	A-XPF M6 x 1 1P
Work Material	SCM440 (30HRC)
Drill Hole Size	Ø5,52 x 15mm (Blind)
Tapping Length	12mm
Cutting Speed	10m/min (530 min ⁻¹)
Coolant	Water Soluble Chlorine Free (5%)
Machine	Horizontal Machining Center

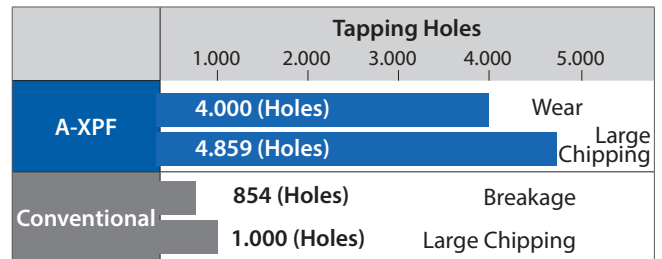

Small diameter threading

Tool	A-XPF M1 x 0,25 1P
Work Material	SUS420J2(192HBW)
Drill Hole Size	Ø0,91 x 3,5mm (Blind)
Tapping Length	2mm (2D)
Cutting Speed	10m/min (3.183 min ⁻¹)
Coolant	Water Soluble Chlorine Free (5%)
Machine	Vertical Machining Center

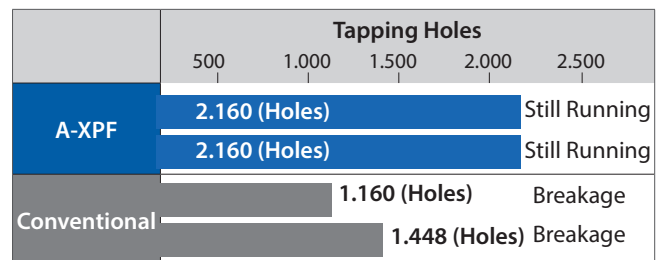

Stable durability with special thread specification

Tool	A-XPF M3 x 0,5 1P
Work Material	SUS304
Drill Hole Size	Ø2,8 x 9mm (Blind)
Tapping Length	6mm (2D)
Cutting Speed	10m/min (1,061 min ⁻¹)
Coolant	Water Soluble Chlorine Free (5%)
Machine	Vertical Machining Center

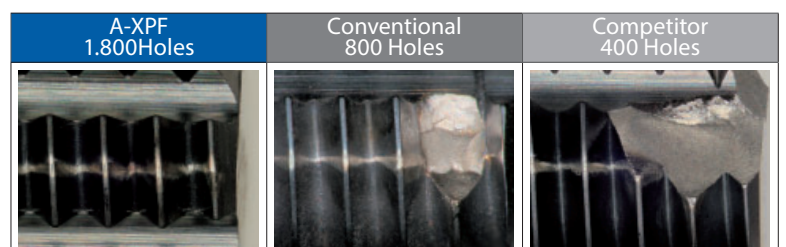
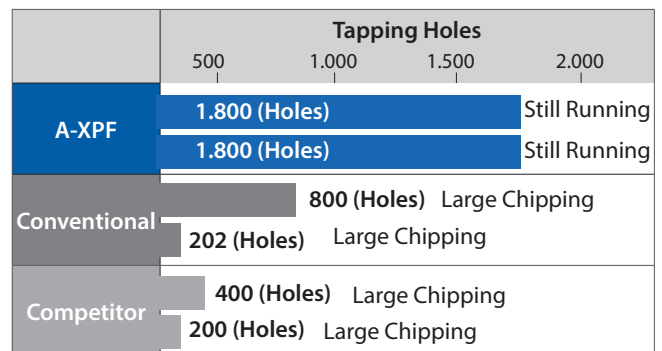

CUTTING DATA

Stable machining with special chamfer specification and VI Coating™

Large thread

Thrust reduction

Tool	A-XPF M16 x 1,5 2P
Work Material	SCM440 (30HRC)
Drill Hole Size	Ø15,3 x 30mm (Through)
Tapping Length	30mm
Cutting Speed	15m/min (298 min ⁻¹)
Coolant	Water Soluble Chlorine Free (5%)
Machine	Horizontal Machining Center

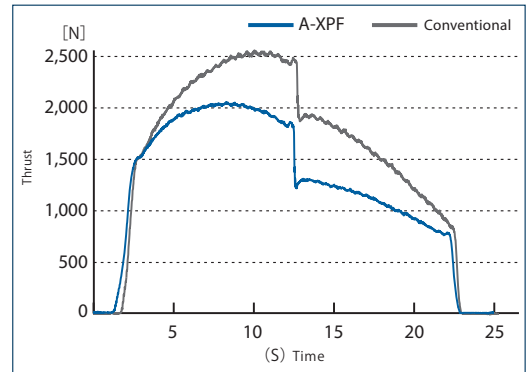

Stable durability in high-hardness material

Tool	A-XPF M16 x 1,5 2P
Work Material	SCM440(30HRC)
Drill Hole Size	Ø15,3 x 30mm (Through)
Tapping Length	30mm
Cutting Speed	15m/min (298 min ⁻¹)
Coolant	Water Soluble Chlorine Free (5%)
Machine	Horizontal Machining Center

	Tapping Holes				
	1.000	2.000	3.000	4.000	5.000
A-XPF	4.480 (Holes)				Wear
	4.480 (Holes)				Wear
Conventional	2.560 (Holes)		Wear		
	2.560 (Holes)		Wear		

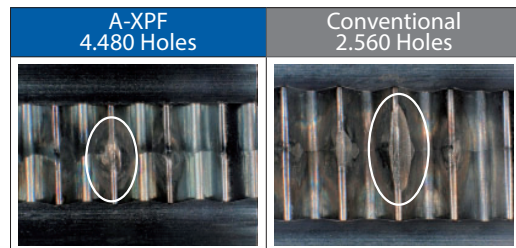

Stable machining by suppressing work hardening during pre-hole drilling



ADO-SUS

Carbide Drill Series for Stainless Steel and Titanium Alloy

- ① Sharp Cutting Edge
Reduces cutting resistance and suppresses work hardening
- ② New oil hole shape "MEGA COOLER"
increases coolant flow

PAT. in Japan

MEGA COOLER is a registered trademark of OSG Corporation.

Work Hardness Near Hole Entry

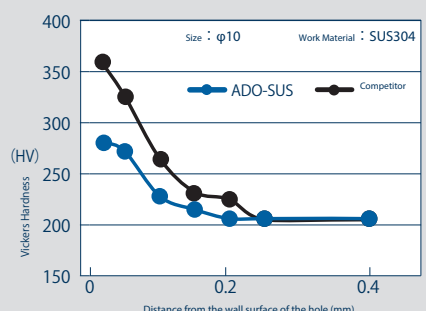

A-XPf

Threading | Forming taps | Metric



- First choice in quality and performance
- Powder metal forming tap for through and blind holes
- Multilayer VI coating
- High speed tapping in general steels, aluminium, stainless steels
- Powder metal for long tool life

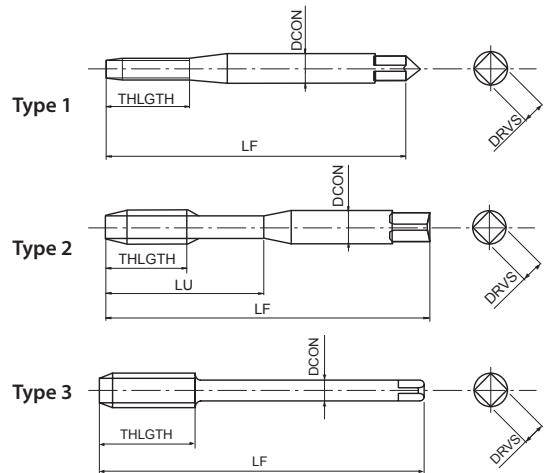

Threading | Forming taps

P C < 0,2%	P 0,25 < C < 0,4	P C ≥ 0,45%	P SCM	M INOX	N Al	N AC, ADC	H 25-35 HRC	
15-40	15-40	15-30	15-30	8-20	20-50	20-40	5-20	m/min

A	M	PM	V D > M16	VI D ≤ M16	ISO 2 6HX	C/2,5			DIN 2174	DIN 2174
----------	----------	-----------	---------------------	----------------------	------------------	--------------	--	--	-----------------	-----------------

*Tolerance 4 HX

EDP	TD	TP	LF	THLGTH	LU	DCON	DRVS	NOF	PHD	Type	DIN
*48133111	1	0,25	40	5,5	-	2,5	2,1	4	0,89 ~ 0,90	1	2174
*48133112	1,1	0,25	40	5,5	-	2,5	2,1	4	0,99 ~ 1,00	1	2174
*48133113	1,2	0,25	40	5,5	-	2,5	2,1	4	1,09 ~ 1,10	1	2174
*48133115	1,4	0,3	40	7	-	2,5	2,1	4	1,26 ~ 1,28	1	2174
48133118	1,6	0,35	40	8	-	2,5	2,1	4	1,45 ~ 1,48	1	2174
48133119	1,7	0,35	40	8	-	2,5	2,1	4	1,55 ~ 1,58	1	2174
48133120	1,8	0,35	40	8	-	2,5	2,1	4	1,65 ~ 1,68	1	2174
48133125	2	0,4	45	8	-	2,8	2,1	5	1,82 ~ 1,85	1	2174
48133127	2,2	0,45	45	9	-	2,8	2,1	5	2,00 ~ 2,04	1	2174
48133128	2,3	0,4	45	9	-	2,8	2,1	5	2,12 ~ 2,15	1	2174
48133133	2,5	0,45	50	9	-	2,8	2,1	5	2,30 ~ 2,34	1	2174
48133136	2,6	0,45	50	9	-	2,8	2,1	5	2,40 ~ 2,44	1	2174
48133138	3	0,5	56	8	18	3,5	2,7	5	2,77 ~ 2,82	2	2174
48133142	3,5	0,6	56	9	20	4	3	5	3,23 ~ 3,28	2	2174
48133144	4	0,7	63	11	21	4,5	3,4	5	3,66 ~ 3,72	2	2174
48133147	4,5	0,75	70	12	25	6	4,9	5	4,14 ~ 4,20	2	2174
48133149	5	0,8	70	12	25	6	4,9	6	4,62 ~ 4,68	2	2174
48133152	5,5	0,9	80	12	30	6	4,9	6	5,06 ~ 5,13	2	2174
48133155	6	1	80	10	30	6	4,9	6	5,51 ~ 5,59	2	2174
48133158	7	1	80	10	30	7	5,5	6	6,51 ~ 6,59	2	2174
48133161	8	1,25	90	12	35	8	6,2	6	7,37 ~ 7,45	2	2174
48133165	9	1,25	90	12	35	9	7	6	8,37 ~ 8,45	2	2174
48133169	10	1,5	100	15	39	10	8	8	9,24 ~ 9,33	2	2174
48133175	11	1,5	100	15	-	8	6,2	8	10,24 ~ 10,33	3	2174
48133179	12	1,75	110	17	-	9	7	9	11,10 ~ 11,20	3	2174
48133191	14	2	110	20	-	11	9	9	12,96 ~ 13,08	3	2174
48133202	16	2	110	20	-	12	9	9	14,96 ~ 15,08	3	2174
48133214	18	2,5	125	20	-	14	11	8	16,66 ~ 16,81	3	2174
48133228	20	2,5	140	20	-	16	12	8	18,66 ~ 18,81	3	2174
48133238	22	2,5	140	20	-	18	14,5	8	20,66 ~ 20,81	3	2174
48133247	24	3	160	24	-	18	14,5	8	22,39 ~ 22,56	3	2174
48133262	27	3	160	18	-	20	16	8	25,39 ~ 25,56	3	2174
48133271	30	3,5	180	21	-	22	18	8	28,09 ~ 28,68	3	2174

A-OIL-XPF NEW SIZE

Threading | Forming taps | Metric

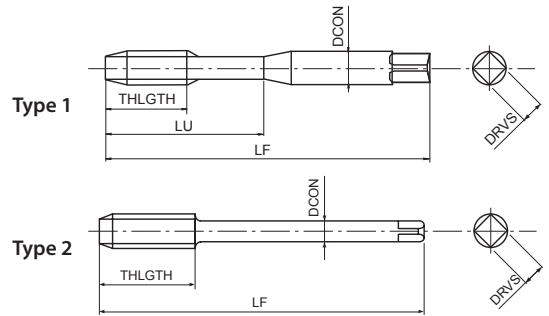
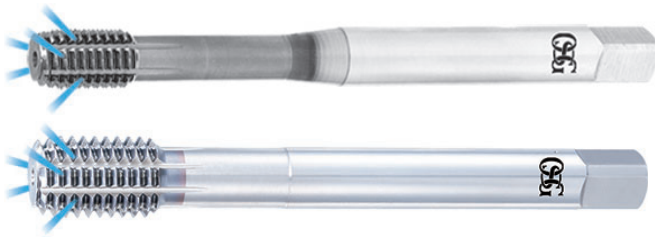

- First choice in quality and performance
- Powder metal forming tap for through and blind holes
- Multilayer TiCN coating
- High speed tapping in general steels, aluminium, stainless steels
- Side through coolant

P C < 0,2%	P 0,25 < C < 0,4	P C ≥ 0,45%	P SCM	M INOX	N Al	N AC, ADC	H 25-35 HRC	
15-40	15-40	15-30	15-30	8-20	20-50	20-40	5-20	m/min

A	M	PM	V	ISO 2 6HX	C/2,5	DIN 2174	DIN 2174
----------	----------	-----------	----------	------------------	--------------	-----------------	-----------------

* Center through coolant

EDP	TD	TP	LF	THLGTH	LU	DCON	DRVS	NOF	PHD	Type	DIN
48225144 *NEW	4	0,7	63	11	21	4,5	3,4	5	3,66~3,72	1	2174
48225149	5	0,8	70	12	25	6	4,9	5	4,62 ~ 4,68	1	2174
48225155	6	1	80	10	30	6	4,9	5	5,51 ~ 5,59	1	2174
48225161	8	1,25	90	12	35	8	6,2	5	7,37 ~ 7,45	1	2174
48225169	10	1,5	100	15	39	10	8	8	9,24 ~ 9,33	1	2174
48225179	12	1,75	110	17	-	9	7	8	11,10 ~ 11,20	2	2174
48225191	14	2	110	20	-	11	9	8	12,96 ~ 13,08	2	2174
48225202	16	2	110	20	-	12	9	8	14,96 ~ 15,08	2	2174
48225214	18	2,5	125	20	-	14	11	8	16,66 ~ 16,81	2	2174
48225228	20	2,5	140	20	-	16	12	8	18,66 ~ 18,81	2	2174
48225238	22	2,5	140	20	-	18	14,5	8	20,66 ~ 20,81	2	2174
48225247	24	3	160	24	-	18	14,5	8	22,39 ~ 22,56	2	2174
48225262	27	3	160	18	-	20	16	8	25,39 ~ 25,56	2	2174
48225271	30	3,5	180	21	-	22	18	8	28,09 ~ 28,28	2	2174
48225281	33	3,5	180	21	-	25	20	8	31,09 ~ 31,28	2	2174
48225294	36	4	200	32	-	28	22	8	33,80 ~ 34,01	2	2174
48225304	39	4	200	32	-	32	24	9	36,80 ~ 37,01	2	2174
48225314	42	4,5	200	36	-	32	24	9	39,52 ~ 39,73	2	2174
48225319	45	4,5	220	36	-	36	29	9	42,52 ~ 42,73	2	2174

Threading | Forming taps

Metric

A-XPf 6GX NEW

Threading | Forming taps | Metric



- First choice in quality and performance
- Powder metal forming tap for through and blind holes
- Multilayer VI coating
- High speed tapping in general steels, aluminium, stainless steels
- For 6G internal thread tolerance

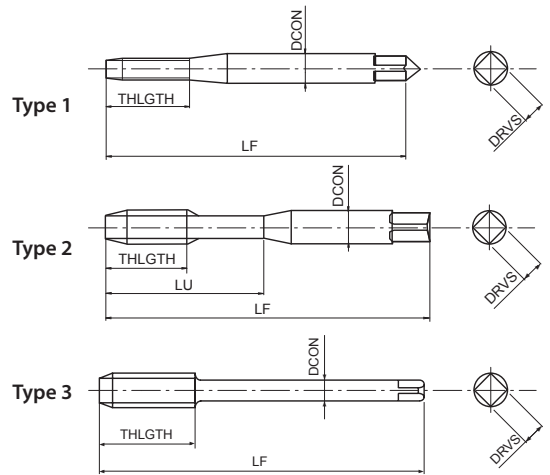

Threading | Forming taps
Metric

P C < 0,2%	P 0,25 < C < 0,4	P C ≥ 0,45%	P SCM	M INOX	N Al	N AC, ADC	H 25-35 HRC			m/min
15-40	15-40	15-30	15-30	8-20	20-50	20-40	5-20			

A	M	PM	VI	ISO 3 6GX	C/2,5	DIN 2174	DIN 2174
----------	----------	-----------	-----------	------------------	--------------	-----------------	-----------------

EDP	TD	TP	Oversize	LF	THLGTH	LU	DCON	DRVS	NOF	PHD	Type	DIN
48434125	2	0,4	0,019	45	8	-	2,8	2,1	5	1,85 ~ 1,88	1	2174
48434138	3	0,5	0,02	56	8	18	3,5	2,7	5	2,79 ~ 2,83	2	2174
48434144	4	0,7	0,022	63	11	21	4,5	3,4	5	3,69 ~ 3,75	2	2174
48434149	5	0,8	0,024	70	12	25	6	4,9	6	4,64 ~ 4,71	2	2174
48434155	6	1	0,026	80	10	30	6	4,9	6	5,55 ~ 5,63	2	2174
48434161	8	1,25	0,028	90	12	35	8	6,2	6	7,40 ~ 7,47	2	2174
48434169	10	1,5	0,032	100	15	39	10	8	8	9,26 ~ 9,35	2	2174
48434179	12	1,75	0,034	110	17	-	9	7	9	11,14 ~ 11,24	3	2174
48434202	16	2	0,038	110	20	-	12	9	9	15,00 ~ 15,12	3	2174

A-XPF 7GX NEW

Threading | Forming taps | Metric

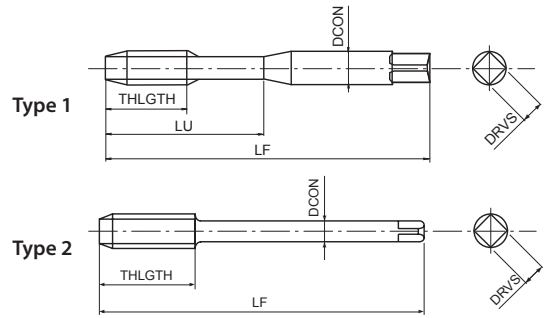

- First choice in quality and performance
- Powder metal forming tap for through and blind holes
- Multilayer VI coating
- High speed tapping in general steels, aluminium, stainless steels
- For 7G internal thread tolerance

P C < 0,2%	P 0,25 < C < 0,4	P C ≥ 0,45%	P SCM	M INOX	N Al	N AC, ADC	H 25-35 HRC	
15-40	15-40	15-30	15-30	8-20	20-50	20-40	5-20	m/min

A	M	PM	VI	7GX	C/2,5	DIN 2174	DIN 2174
----------	----------	-----------	-----------	------------	--------------	-----------------	-----------------

EDP	TD	TP	Oversize	LF	THLGTH	LU	DCON	DRVS	NOF	PHD	Type	DIN
48435138	3	0,5	0,04	56	8	18	3,5	2,7	5	2,81 ~ 2,85	1	2174
48435144	4	0,7	0,044	63	11	21	4,5	3,4	5	3,71 ~ 3,77	1	2174
48435149	5	0,8	0,048	70	12	25	6	4,9	6	4,67 ~ 4,73	1	2174
48435155	6	1	0,052	80	10	30	6	4,9	6	5,56 ~ 5,64	1	2174
48435161	8	1,25	0,056	90	12	35	8	6,2	6	7,42 ~ 7,50	1	2174
48435169	10	1,5	0,064	100	15	39	10	8	8	9,30 ~ 9,39	1	2174
48435179	12	1,75	0,068	110	17	-	9	7	9	11,17 ~ 11,28	2	2174



A-XPFORM E NEW

Threading | Forming taps | Metric



- First choice in quality and performance
- Powder metal forming tap for through and blind holes
- Multilayer VI coating
- High speed tapping in general steels, aluminium, stainless steels
- Form E chamfer

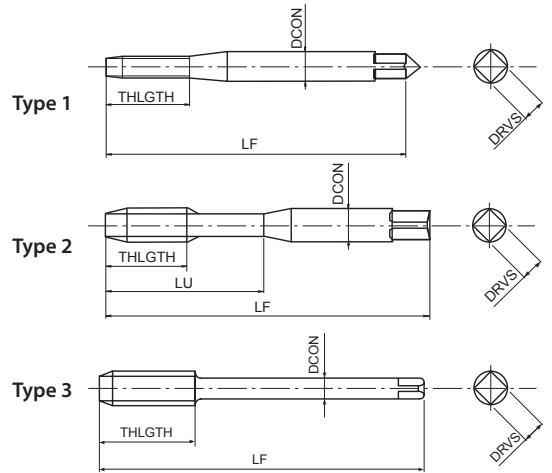

Threading | Forming taps

P C < 0,2%	P 0,25 < C < 0,4	P C ≥ 0,45%	P SCM	M INOX	N Al	N AC, ADC	H 25-35 HRC	
15-40	15-40	15-30	15-30	8-20	20-50	20-40	5-20	m/min

A	M	PM	VI	ISO 2 6HX	E/1,5	DIN 2174	DIN 2174
----------	----------	-----------	-----------	------------------	--------------	-----------------	-----------------

EDP	TD	TP	LF	THLGTH	LU	DCON	DRVS	NOF	PHD	Type	DIN
48436125	2	0,4	45	8	-	2,8	2,1	5	1,82 ~ 1,85	1	2174
48436138	3	0,5	56	8	18	3,5	2,7	5	2,77 ~ 2,82	2	2174
48436144	4	0,7	63	11	21	4,5	3,4	5	3,66 ~ 3,72	2	2174
48436149	5	0,8	70	12	25	6	4,9	6	4,62 ~ 4,68	2	2174
48436155	6	1	80	10	30	6	4,9	6	5,51 ~ 5,59	2	2174
48436161	8	1,25	90	12	35	8	6,2	6	7,37 ~ 7,45	2	2174
48436169	10	1,5	100	15	39	10	8	8	9,24 ~ 9,33	2	2174
48436179	12	1,75	110	17	-	9	7	9	11,10 ~ 11,20	3	2174
48436202	16	2	110	20	-	12	9	9	14,96 ~ 15,08	3	2174

Metric

A-OIL-XPF FORM E NEW

Threading | Forming taps | Metric

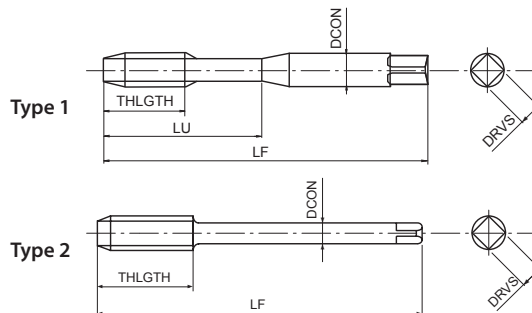
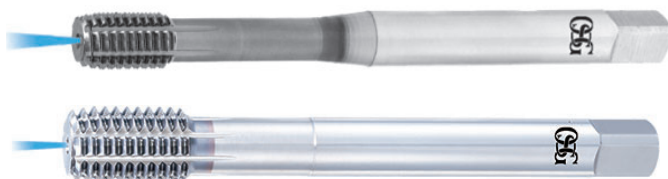

- First choice in quality and performance
- Powder metal forming tap for blind holes
- Multilayer VI coating
- High speed tapping in general steels, aluminium, stainless steels
- Centre through coolant, Form E chamfer

P	P	P	P	M	N	N	H		
C < 0,2%	0,25 < C < 0,4	C ≥ 0,45%	SCM	INOX	Al	AC, ADC	25-35 HRC		
15-40	15-40	15-30	15-30	8-20	20-50	20-40	5-20		m/min
A	M	PM	VI	ISO 2 6HX					
				E/1,5			DIN 2174	DIN 2174	

EDP	TD	TP	LF	THLGTH	LU	DCON	DRVS	NOF	PHD	Type	DIN
48437144	4	0,7	63	11	21	4,5	3,4	5	3,66~3,72	1	2174
48437149	5	0,8	70	12	25	6	4,9	6	4,62 ~ 4,68	1	2174
48437155	6	1	80	10	30	6	4,9	6	5,51 ~ 5,59	1	2174
48437161	8	1,25	90	12	35	8	6,2	6	7,37 ~ 7,45	1	2174
48437169	10	1,5	100	15	39	10	8	8	9,24 ~ 9,33	1	2174
48437179	12	1,75	110	17	-	9	7	9	11,10 ~ 11,20	2	2174
48437202	16	2	110	20	-	12	9	9	14,96 ~ 15,08	2	2174



Metric

S-XPf

Threading | Forming taps | Metric



- First choice in quality and performance
- HSE forming tap for through and blind holes
- Multilayer TiCN coating
- For general steels, stainless steels, aluminium

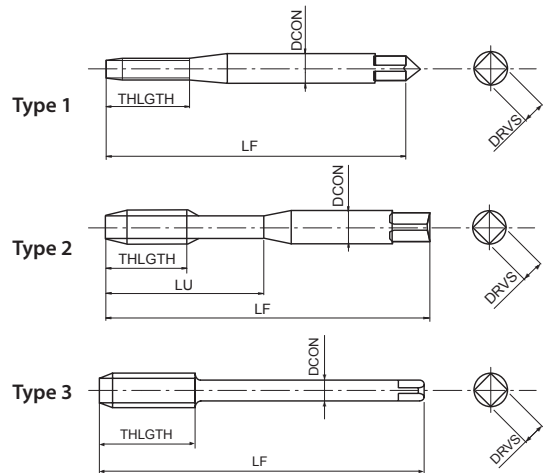

Threading | Forming taps

P C < 0,2%	P 0,25 < C < 0,4	P C ≥ 0,45%	P SCM	M INOX	N Al	N AC, ADC	H 25-35 HRC	
15-40	15-40	15-30	15-30	8-20	20-50	20-40	5-20	m/min

A	M	HSS-Co	V	ISO 2 6HX	C/2,5	DIN 2174	DIN 2174
----------	----------	---------------	----------	------------------	--------------	-----------------	-----------------

EDP	TD	TP	LF	THLGTH	LU	DCON	DRVS	NOF	PHD	Type	DIN
48030111	1	0,25	40	5,50	-	2,5	2,1	4	0,89 ~ 0,90	1	2174
48030112	1,1	0,25	40	5,50	-	2,5	2,1	4	0,99 ~ 1,00	1	2174
48030113	1,2	0,25	40	6	-	2,5	2,1	4	1,09 ~ 1,10	1	2174
48030115	1,4	0,3	40	7	-	2,5	2,1	4	1,26 ~ 1,28	1	2174
48030118	1,6	0,35	40	8	-	2,5	2,1	4	1,45 ~ 1,48	1	2174
48030119	1,7	0,35	40	8	-	2,5	2,1	4	1,55 ~ 1,58	1	2174
48030120	1,8	0,35	40	8	-	2,5	2,1	4	1,65 ~ 1,68	1	2174
48030125	2	0,4	45	8	-	2,8	2,1	4	1,82 ~ 1,85	1	2174
48030127	2,2	0,45	45	9	-	2,8	2,1	4	2,00 ~ 2,04	1	2174
48030128	2,3	0,4	45	9	-	2,8	2,1	4	2,12 ~ 2,15	1	2174
48030133	2,5	0,45	50	9	-	2,8	2,1	4	2,30 ~ 2,34	1	2174
48030136	2,6	0,45	50	9	-	2,8	2,1	4	2,40 ~ 2,44	1	2174
48030138	3	0,5	56	8	18	3,5	2,7	4	2,77 ~ 2,82	2	2174
48030142	3,5	0,6	56	9	20	4	3	4	3,23 ~ 3,28	2	2174
48030144	4	0,7	63	11	21	4,5	3,4	4	3,67 ~ 3,72	2	2174
48030147	4,5	0,75	70	12	25	6	4,9	5	4,14 ~ 4,20	2	2174
48030149	5	0,8	70	12	25	6	4,9	5	4,62 ~ 4,68	2	2174
48030152	5,5	0,9	80	12	30	6	4,9	5	5,06 ~ 5,13	2	2174
48030155	6	1	80	10	30	6	4,9	5	5,51 ~ 5,59	2	2174
48030158	7	1	80	10	30	7	5,5	5	6,51 ~ 6,59	2	2174
48030161	8	1,25	90	12	35	8	6,2	5	7,37 ~ 7,45	2	2174
48030165	9	1,25	90	12	35	9	7	8	8,37 ~ 8,45	2	2174
48030169	10	1,5	100	15	39	10	8	8	9,24 ~ 9,33	2	2174
48030175	11	1,5	100	15	-	8	6,2	8	10,24 ~ 10,33	3	2174
48030179	12	1,75	110	17	-	9	7	8	11,10 ~ 11,20	3	2174
48030191	14	2	110	20	-	11	9	8	12,96 ~ 13,08	3	2174
48030202	16	2	110	20	-	12	9	8	14,96 ~ 15,08	3	2174
48069214	18	2,5	125	20	-	14	11	8	16,66 ~ 16,81	3	2174
48069228	20	2,5	140	20	-	16	12	8	18,66 ~ 18,81	3	2174
48069238	22	2,5	140	20	-	18	14,5	8	20,66 ~ 20,81	3	2174
48069247	24	3	160	24	-	18	14,5	8	22,39 ~ 22,56	3	2174
48069262	27	3	160	18	-	20	16	8	25,39 ~ 25,56	3	2174
48069271	30	3,5	180	21	-	22	18	8	28,09 ~ 28,28	3	2174

S-OIL-XPF NEW SIZE

Threading | Forming taps | Metric

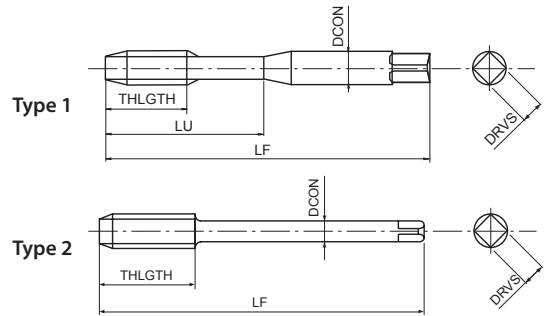

- First choice in quality and performance
- HSE forming tap for through and blind holes
- Multilayer TiCN coating
- For general steels, stainless steels, aluminium
- Side through coolant

P C < 0,2%	P 0,25 < C < 0,4	P C ≥ 0,45%	P SCM	M INOX	N Al	N AC, ADC	H 25-35 HRC	
15-40	15-40	15-30	15-30	8-20	20-50	20-40	5-20	m/min

A	M	HSS-Co	V	ISO 2 6HX	C/2,5	DIN 2174	DIN 2174
----------	----------	---------------	----------	------------------	--------------	-----------------	-----------------

* Center through coolant

EDP	TD	TP	LF	THLGTH	LU	DCON	DRVS	NOF	PHD	Type	DIN
48042144*	4	0,7	63	11	21	4,5	3,4	4	3,67~3,72	1	2174
48042149	5	0,8	70	12	25	6	4,9	5	4,62 ~ 4,68	1	2174
48042155	6	1	80	10	30	6	4,9	5	5,51 ~ 5,59	1	2174
48042161	8	1,25	90	12	35	8	6,2	5	7,37 ~ 7,45	1	2174
48042169	10	1,5	100	15	39	10	8	8	9,24 ~ 9,33	1	2174
48042179	12	1,75	110	17	-	9	7	8	11,10 ~ 11,20	2	2174
48042191	14	2	110	20	-	11	9	8	12,96 ~ 13,08	2	2174
48042202	16	2	110	20	-	12	9	8	14,96 ~ 15,08	2	2174
48071214	18	2,5	125	20	-	14	11	8	16,66 ~ 16,81	2	2174
48071228	20	2,5	140	20	-	16	12	8	18,66 ~ 18,81	2	2174
48071238	22	2,5	140	20	-	18	14,5	8	20,66 ~ 20,81	2	2174
48071247	24	3	160	24	-	18	14,5	8	22,39 ~ 22,56	2	2174
48071262	27	3	160	18	-	20	16	8	25,39 ~ 25,56	2	2174
48071271	30	3,5	180	21	-	22	18	8	28,09 ~ 28,28	2	2174
48071281	33	3,5	180	21	-	25	20	8	31,09 ~ 31,28	2	2174
48071294	36	4	200	24	-	28	22	8	33,80 ~ 34,01	2	2174
48071304	39	4	200	24	-	32	24	9	36,80 ~ 37,01	2	2174
48071314	42	4,5	200	27	-	32	24	9	39,52 ~ 39,73	2	2174
48071319	45	4,5	220	27	-	36	29	9	42,52 ~ 42,73	2	2174

S-XPF 6GX

Threading | Forming taps | Metric

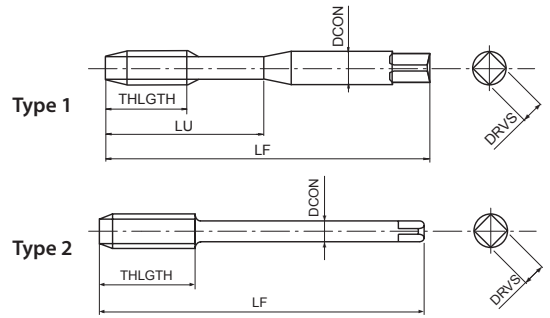

- First choice in quality and performance
- HSE forming tap for through and blind holes
- Multilayer TiCN coating
- For general steels, stainless steels, aluminium
- For 6G internal thread tolerance

Threading | Forming taps

P C < 0,2%	P 0,25 < C < 0,4	P C ≥ 0,45%	P SCM	M INOX	N Al	N AC, ADC	H 25-35 HRC		m/min
15-40	15-40	15-30	15-30	8-20	20-50	20-40	5-20		

A	M	HSS-Co	V	ISO 3 6GX	C/2,5	DIN 2174	DIN 2174
----------	----------	---------------	----------	------------------	--------------	-----------------	-----------------

Metric

EDP	TD	TP	Oversize	LF	THLGTH	LU	DCON	DRVS	NOF	PHD	Type	DIN
48086125	2	0,4	0,0190	45	-	8	2,8	2,1	4	1,85 ~ 1,88	1	2174
48086133	2,5	0,45	0,0200	50	-	9	2,8	2,1	4	2,32 ~ 2,35	1	2174
48086138	3	0,5	0,0200	56	-	18	3,5	2,7	4	2,79 ~ 2,83	1	2174
48086142	3,5	0,6	0,0210	56	-	20	4	3	4	3,24 ~ 3,29	1	2174
48086144	4	0,7	0,0220	63	-	21	4,5	3,4	4	3,69 ~ 3,75	1	2174
48086149	5	0,8	0,0240	70	-	25	6	4,9	5	4,64 ~ 4,71	1	2174
48086155	6	1	0,0260	80	-	30	6	4,9	5	5,55 ~ 5,63	1	2174
48086161	8	1,25	0,0280	90	-	35	8	6,2	5	7,40 ~ 7,47	1	2174
48086169	10	1,5	0,0320	100	-	39	10	8	8	9,26 ~ 9,35	1	2174
48086179	12	1,75	0,0340	110	17	-	9	7	8	11,14 ~ 11,24	2	2174
48086191	14	2	0,0380	110	20	-	11	9	8	13,00 ~ 13,12	2	2174
48086202	16	2	0,0380	110	20	-	12	9	8	15,00 ~ 15,12	2	2174

S-OIL-XPF 6GX

Threading | Forming taps | Metric

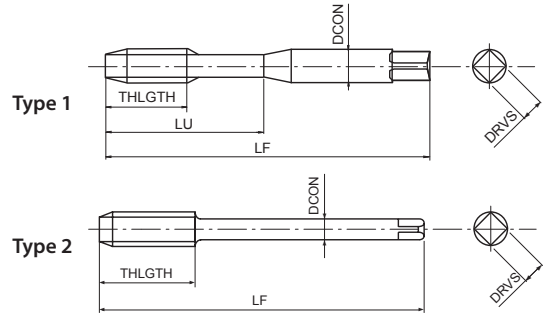

- First choice in quality and performance
- HSE forming tap for through and blind holes
- Multilayer TiCN coating
- For general steels, stainless steels, aluminium
- For 6G internal thread tolerance, side through coolant

P	P	P	P	M	N	N	H	m/min
C < 0,2%	0,25 < C < 0,4	C ≥ 0,45%	SCM	INOX	Al	AC, ADC	25-35 HRC	
15-40	15-40	15-30	15-30	8-20	20-50	20-40	5-20	

A	M	HSS-Co	V	ISO 3 6GX					DIN 2174	DIN 2174
----------	----------	---------------	----------	------------------	--	--	--	--	-----------------	-----------------

EDP	TD	TP	Oversize	LF	THLGTH	LU	DCON	DRVS	NOF	PHD	Type	DIN
48293149	5	0,8	0,0240	70	-	25	6	4,9	5	4,64 ~ 4,71	1	2174
48293155	6	1	0,0260	80	-	30	6	4,9	5	5,55 ~ 5,63	1	2174
48293161	8	1,25	0,0280	90	-	35	8	6,2	5	7,40 ~ 7,47	1	2174
48293169	10	1,5	0,0320	100	-	39	10	8	8	9,26 ~ 9,35	1	2174
48293179	12	1,75	0,0340	110	18	-	9	7	8	11,14 ~ 11,24	2	2174
48293191	14	2	0,0380	110	20	-	11	9	8	13,00 ~ 13,12	2	2174
48293202	16	2	0,0380	110	20	-	12	9	8	15,00 ~ 15,12	2	2174

S-XPF 7GX

Threading | Forming taps | Metric

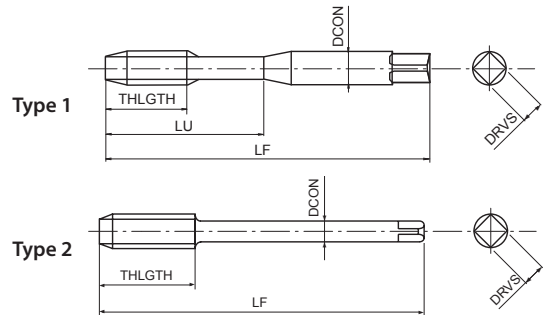

- First choice in quality and performance
- HSE forming tap for through and blind holes
- Multilayer TiCN coating
- For general steels, stainless steels, aluminium
- For 7G internal thread tolerance

Threading | Forming taps

P C < 0,2%	P 0,25 < C < 0,4	P C ≥ 0,45%	P SCM	M INOX	N Al	N AC, ADC	H 25-35 HRC	
15-40	15-40	15-30	15-30	8-20	20-50	20-40	5-20	m/min

A	M	HSS-Co	V	7GX	C/2,5	DIN 2174	DIN 2174
----------	----------	---------------	----------	------------	--------------	-----------------	-----------------

EDP	TD	TP	Oversize	LF	THLGTH	LU	DCON	DRVS	NOF	PHD	Type	DIN
48087125	2	0,4	0,0380	45	-	8	2,8	2,1	4	1,86 ~ 1,90	1	2174
48087133	2,5	0,45	0,0400	50	-	9	2,8	2,1	4	2,34 ~ 2,38	1	2174
48087138	3	0,5	0,0400	56	-	18	3,5	2,7	4	2,81 ~ 2,85	1	2174
48087142	3,5	0,6	0,0440	56	-	20	4	3	4	3,27 ~ 3,31	1	2174
48087144	4	0,7	0,0440	63	-	21	4,5	3,4	4	3,71 ~ 3,77	1	2174
48087149	5	0,8	0,0480	70	-	25	6	4,9	5	4,67 ~ 4,73	1	2174
48087155	6	1	0,0520	80	-	30	6	4,9	5	5,56 ~ 5,64	1	2174
48087161	8	1,25	0,0560	90	-	35	8	6,2	5	7,42 ~ 7,50	1	2174
48087169	10	1,5	0,0640	100	-	39	10	8	8	9,30 ~ 9,39	1	2174
48087179	12	1,75	0,0680	110	17	-	9	7	8	11,17 ~ 11,28	2	2174
48087191	14	2	0,0760	110	20	-	11	9	8	13,04 ~ 13,16	2	2174
48087202	16	2	0,0760	110	20	-	12	9	8	15,04 ~ 15,16	2	2174

Metric

S-XPF FORM D

Threading | Forming taps | Metric

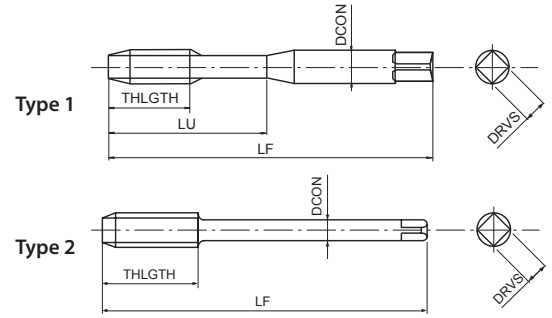

- First choice in quality and performance
- HSE forming tap for through holes
- Multilayer TiCN coating
- For general steels, stainless steels, aluminium
- Chamfer Form D

Threading | Forming taps
Metric

P C < 0,2%	P 0,25 < C < 0,4	P C ≥ 0,45%	P SCM	M INOX	N Al	N AC, ADC	H 25-35 HRC	5-20	m/min
15-40	15-40	15-30	15-30	8-20	20-50	20-40			

A	M	HSS-Co	V	ISO 2 6HX	D/4	DIN 2174	DIN 2174
----------	----------	---------------	----------	------------------	------------	-----------------	-----------------

EDP	TD	TP	LF	THLGTH	LU	DCON	DRVS	NOF	PHD	Type	DIN
48088138	3	0,5	56	-	18	3,5	2,7	4	2,77~2,82	1	2174
48088144	4	0,7	63	-	21	4,5	3,4	4	3,67~3,72	1	2174
48088149	5	0,8	70	-	25	6	4,9	5	4,62~4,68	1	2174
48088155	6	1	80	-	30	6	4,9	5	5,51~5,59	1	2174
48088161	8	1,25	90	-	35	8	6,2	5	7,37~7,45	1	2174
48088169	10	1,5	100	-	39	10	8	8	9,24~9,33	1	2174
48088179	12	1,75	110	17	-	9	7	8	11,10~11,20	2	2174
48088191	14	2	110	20	-	11	9	8	12,96~13,08	2	2174
48088202	16	2	110	20	-	12	9	8	14,96~15,08	2	2174

S-XPF FORM E

Threading | Forming taps | Metric

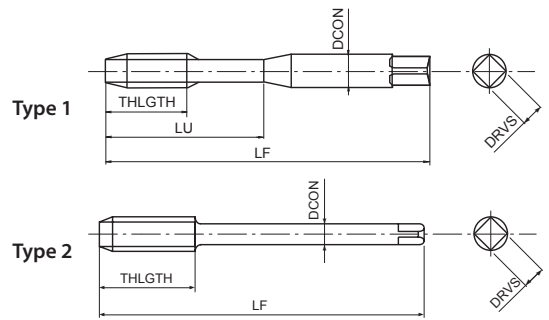

- First choice in quality and performance
- HSE forming tap for through and blind holes
- Multilayer TiCN coating
- For general steels, stainless steels, aluminium
- Chamfer Form E

P C < 0,2%	P 0,25 < C < 0,4	P C ≥ 0,45%	P SCM	M INOX	N Al	N AC, ADC	H 25-35 HRC	
15-40	15-40	15-30	15-30	8-20	20-50	20-40	5-20	m/min

A	M	HSS-Co	V	ISO 2 6HX	E/1,5	DIN 2174	DIN 2174
----------	----------	---------------	----------	------------------	--------------	-----------------	-----------------

EDP	TD	TP	LF	THLGTH	LU	DCON	DRVS	NOF	PHD	Type	DIN
48089125	2	0,4	45	-	8	2,8	2,1	4	1,82 ~ 1,85	1	2174
48089133	2,5	0,45	50	-	9	2,8	2,1	4	2,30 ~ 2,34	1	2174
48089138	3	0,5	56	-	18	3,5	2,7	4	2,77 ~ 2,82	1	2174
48089142	3,5	0,6	56	-	20	4	3	4	3,23 ~ 3,28	1	2174
48089144	4	0,7	63	-	21	4,5	3,4	4	3,66 ~ 3,72	1	2174
48089149	5	0,8	70	-	25	6	4,9	5	4,62 ~ 4,68	1	2174
48089155	6	1	80	-	30	6	4,9	5	5,51 ~ 5,59	1	2174
48089161	8	1,25	90	-	35	8	6,2	5	7,37 ~ 7,45	1	2174
48089169	10	1,5	100	-	39	10	8	8	9,24 ~ 9,33	1	2174
48089179	12	1,75	110	17	-	9	7	8	11,10 ~ 11,20	2	2174
48089191	14	2	110	20	-	11	9	8	12,96 ~ 13,08	2	2174
48089202	16	2	110	20	-	12	9	8	14,96 ~ 15,08	2	2174



S-OIL-XP F FORM E NEW SIZE

Threading | Forming taps | Metric

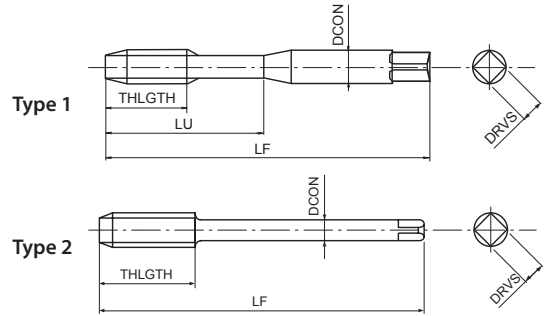

- First choice in quality and performance
- HSE forming tap for blind holes
- Multilayer TiCN coating
- For general steels, stainless steels, aluminium
- Centre through coolant, chamfer Form E

P	P	P	P	M	N	N	H	m/min	
C < 0,2%	0,25 < C < 0,4	C ≥ 0,45%	SCM	INOX	Al	AC, ADC	25-35 HRC		
15-40	15-40	15-30	15-30	8-20	20-50	20-40	5-20		

A	M	HSS-Co	V	ISO 2 6HX	E/1,5		DIN 2174	DIN 2174
----------	----------	--------	----------	----------------------	-------	--	-----------------	-----------------

EDP	TD	TP	LF	THLGTH	LU	DCON	DRVS	NOF	PHD	Type	DIN
48294144	^{NEW} 4	0,7	63	11	21	4,5	3,4	4	3,67~3,72	1	2174
48294149	5	0,8	70	12	25	6	4,9	5	4,62 ~ 4,68	1	2174
48294155	6	1	80	10	30	6	4,9	5	5,51 ~ 5,59	1	2174
48294161	8	1,25	90	12	35	8	6,2	5	7,37 ~ 7,45	1	2174
48294169	10	1,5	100	15	39	10	8	8	9,24 ~ 9,33	1	2174
48294179	12	1,75	110	18	-	9	7	8	11,10 ~ 11,20	2	2174
48294191	14	2	110	20	-	11	9	8	12,96 ~ 13,08	2	2174
48294202	16	2	110	20	-	12	9	8	14,96 ~ 15,08	2	2174

Threading | Forming taps
Metric



- First choice in quality and performance
- HSE forming tap for through and blind holes
- Multilayer TiCN coating
- For general steels, stainless steels, aluminium
- With long shank for long reach threading

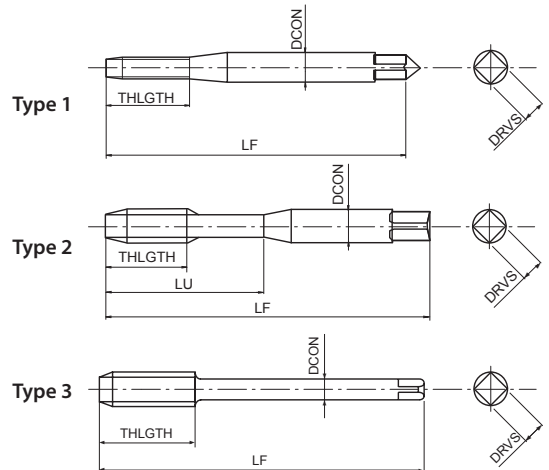

P C < 0,2%	P 0,25 < C < 0,4	P C ≥ 0,45%	P SCM	M INOX	N Al	N AC, ADC	H 25-35 HRC	m/min		
15-40	15-40	15-30	15-30	8-20	20-50	20-40	5-20			

A	M	HSS-Co	V	ISO 2 6HX	C/2,5				
----------	----------	---------------	----------	----------------------	-------	--	--	--	--

EDP	TD	TP	LF	THLGTH	LU	DCON	DRVS	NOF	PHD	Type
48115125	2	0,4	80	-	8	2,8	2,1	0	1,82 ~ 1,85	1
48115133	2,5	0,45	100	-	9	2,8	2,1	0	2,30 ~ 2,34	1
48115138	3	0,5	100	-	18	3,5	2,7	4	2,77 ~ 2,82	2
48115144	4	0,7	125	-	21	4,5	3,4	4	3,67 ~ 3,72	2
48115149	5	0,8	140	-	25	6	4,9	5	4,62 ~ 4,68	2
48115155	6	1	160	-	30	6	4,9	5	5,51 ~ 5,59	2
48115161	8	1,25	180	-	35	8	6,2	5	7,37 ~ 7,45	2
48115169	10	1,5	200	-	39	10	8	8	9,24 ~ 9,33	2
48115179	12	1,75	200	17	-	9	7	8	11,10 ~ 11,20	3

S-OIL-LT-XP

Threading | Forming taps | Metric

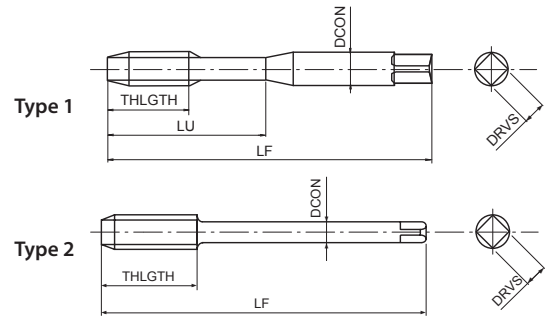

- First choice in quality and performance
- HSE forming tap for through and blind holes
- Multilayer TiCN coating
- For general steels, stainless steels, aluminium
- With long shank for long reach threading, side through coolant

Threading | Forming taps

P	P	P	P	M	N	N	H	
C < 0,2%	0,25 < C < 0,4	C ≥ 0,45%	SCM	INOX	Al	AC, ADC	25-35 HRC	
15-40	15-40	15-30	15-30	8-20	20-50	20-40	5-20	m/min
A	M	HSS-Co	V	ISO 2 6HX				

EDP	TD	TP	LF	THLGTH	LU	DCON	DRVS	NOF	PHD	Type
48295155	6	1	160	-	30	6	4,9	5	5,51 ~ 5,59	1
48295161	8	1,25	180	-	35	8	6,2	5	7,37 ~ 7,45	1
48295169	10	1,5	200	-	39	10	8	8	9,24 ~ 9,33	1
48295179	12	1,75	200	18	-	9	7	8	11,10 ~ 11,20	2

Threading | Forming taps | Metric

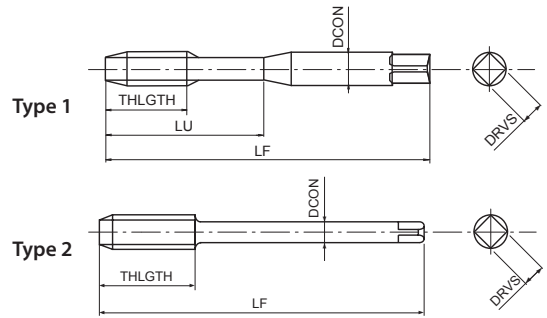

- First choice in quality and performance
- HSE forming tap for through and blind holes
- Multilayer TiCN coating
- For general steels, stainless steels, aluminium
- For left-hand threads

P	P	P	P	M	N	N	H	
C < 0,2%	0,25 < C < 0,4	C ≥ 0,45%	SCM	INOX	Al	AC, ADC	25-35 HRC	m/min
15-40	15-40	15-30	15-30	8-20	20-50	20-40	5-20	

A	M	HSS-Co	V	ISO 2 6HX	C/2,5			DIN 2174	DIN 2174	LH
----------	----------	--------	----------	--------------	-------	--	--	----------	----------	-----------

EDP	TD	TP	LF	THLGTH	LU	DCON	DRVS	NOF	PHD	Type	DIN
48219138	3	0,5	56	-	18	3,5	2,7	4	2,77 ~ 2,82	1	2174
48219144	4	0,7	63	-	21	4,5	3,4	4	3,67 ~ 3,72	1	2174
48219149	5	0,8	70	-	25	6	4,9	5	4,62 ~ 4,68	1	2174
48219155	6	1	80	-	30	6	4,9	5	5,51 ~ 5,59	1	2174
48219161	8	1,25	90	-	35	8	6,2	5	7,37 ~ 7,45	1	2174
48219169	10	1,5	100	-	39	10	8	8	9,24 ~ 9,33	1	2174
48219179	12	1,75	110	17	-	9	7	8	11,10 ~ 11,20	2	2174
48219191	14	2	110	20	-	11	9	8	12,96 ~ 13,08	2	2174
48219202	16	2	110	20	-	12	9	8	14,96 ~ 15,08	2	2174
48219214	18	2,5	125	20	-	14	11	8	16,66 ~ 16,81	2	2174
48219228	20	2,5	140	20	-	16	12	8	18,66 ~ 18,81	2	2174
48219238	22	2,5	140	20	-	18	14,5	8	20,66 ~ 20,81	2	2174
48219247	24	3	160	24	-	18	14,5	8	22,39 ~ 22,56	2	2174



S-XPF-HB Weldon

Threading | Forming taps | Metric

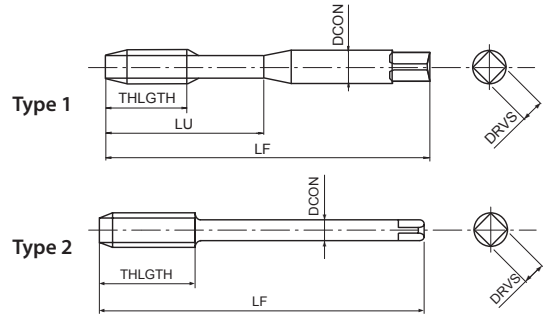

- First choice in quality and performance
- HSE forming tap for through and blind holes
- Multilayer TiCN coating
- For general steels, stainless steels, aluminium
- With Weldon shank

Threading | Forming taps

P C < 0,2%	P 0,25 < C < 0,4	P C ≥ 0,45%	P SCM	M INOX	N Al	N AC, ADC	H 25-35 HRC		m/min
15-40	15-40	15-30	15-30	8-20	20-50	20-40	5-20		

A	M	HSS-Co	V	ISO 2 6HX	C/2,5			DIN 2174	DIN 2174	DIN 1835	HB
----------	----------	--------	----------	-----------	-------	--	--	----------	----------	----------	----

EDP	TD	TP	LF	THLGTH	LU	DCON	DRVS	NOF	PHD	Type	DIN
48222138	3	0,5	56	-	18	6	4,9	4	2,77 ~ 2,82	1	2174/1835
48222144	4	0,7	63	-	21	6	4,9	4	3,67 ~ 3,72	1	2174/1835
48222149	5	0,8	70	-	25	6	4,9	5	4,62 ~ 4,68	1	2174/1835
48222155	6	1	80	-	30	6	4,9	5	5,51 ~ 5,59	1	2174/1835
48222161	8	1,25	90	-	35	8	6,2	5	7,37 ~ 7,45	1	2174/1835
48222169	10	1,5	100	-	39	10	8	8	9,24 ~ 9,33	1	2174/1835
48222179	12	1,75	110	17	-	12	9	8	11,10 ~ 11,20	2	2174/1835
48222191	14	2	110	20	-	14	11	8	12,96 ~ 13,08	2	2174/1835
48222202	16	2	110	20	-	16	12	8	14,96 ~ 15,08	2	2174/1835

Metric

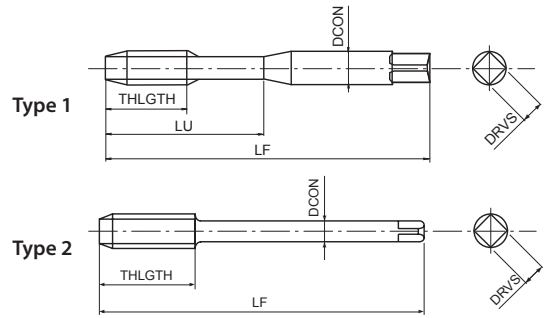

- First choice in quality and performance
- HSE forming tap for through and blind holes
- Multilayer TiCN coating
- For general steels, stainless steels, aluminium
- Without oil grooves for higher rigidity

P C < 0,2%	P 0,25 < C < 0,4	P C ≥ 0,45%	P SCM	M INOX	N Al	N AC, ADC	H 25-35 HRC		
15-40	15-40	15-30	15-30	8-20	20-50	20-40	5-20	m/min	

A	M	HSS-Co	V	ISO 2 6HX	C/2,5	DIN 2174	DIN 2174
----------	----------	---------------	----------	------------------	--------------	-----------------	-----------------

EDP	TD	TP	LF	THLGTH	LU	DCON	DRVS	NOF	PHD	Type	DIN
48296138	3	0,5	56	4	18	3,5	2,7	0	2,77 ~ 2,82	1	2174
48296144	4	0,7	63	5,6	21	4,5	3,4	0	3,67 ~ 3,72	1	2174
48296149	5	0,8	70	6,4	25	6	4,9	0	4,62 ~ 4,68	1	2174
48296155	6	1	80	8	30	6	4,9	0	5,51 ~ 5,59	1	2174
48296161	8	1,25	90	10	35	8	6,2	0	7,37 ~ 7,45	1	2174
48296169	10	1,5	100	12	39	10	8	0	9,24 ~ 9,33	1	2174
48296179	12	1,75	110	17	-	9	7	0	11,10 ~ 11,20	2	2174



S-XPF-GL 6GX

Threading | Forming taps | Metric

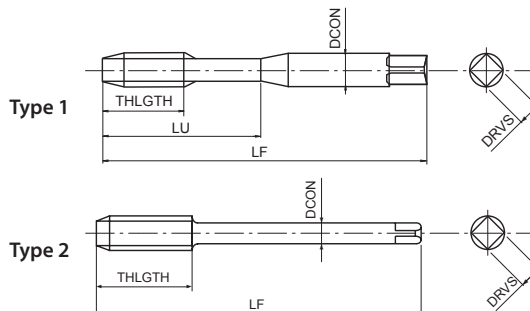

- First choice in quality and performance
- HSE forming tap for through and blind holes
- Multilayer TiCN coating
- For general steels, stainless steels, aluminium
- Without oil grooves for higher rigidity, for 6G internal thread tolerance

Threading | Forming taps

P C < 0,2%	P 0,25 < C < 0,4	P C ≥ 0,45%	P SCM	M INOX	N Al	N AC, ADC	H 25-35 HRC			
15-40	15-40	15-30	15-30	8-20	20-50	20-40	5-20	m/min		

A	M	HSS-Co	V	ISO 3 6GX	C/2,5		DIN 2174	DIN 2174
----------	----------	---------------	----------	----------------------	--------------	--	-----------------	-----------------

EDP	TD	TP	Overdose	LF	THLGTH	LU	DCON	DRVS	NOF	PHD	Type	DIN
48297138	3	0,5	0,0200	56	-	18	3,5	2,7	0	2,79 ~ 2,83	1	2174
48297144	4	0,7	0,0220	63	-	21	4,5	3,4	0	3,69 ~ 3,75	1	2174
48297149	5	0,8	0,0240	70	-	25	6	4,9	0	4,64 ~ 4,71	1	2174
48297155	6	1	0,0260	80	-	30	6	4,9	0	5,55 ~ 5,63	1	2174
48297161	8	1,25	0,0280	90	-	35	8	6,2	0	7,40 ~ 7,47	1	2174
48297169	10	1,5	0,0320	100	-	39	10	8	0	9,26 ~ 9,35	1	2174
48297179	12	1,75	0,0340	110	18	-	9	7	0	11,14 ~ 11,24	2	2174

C-OIL-XPf

Threading | Forming taps | Metric

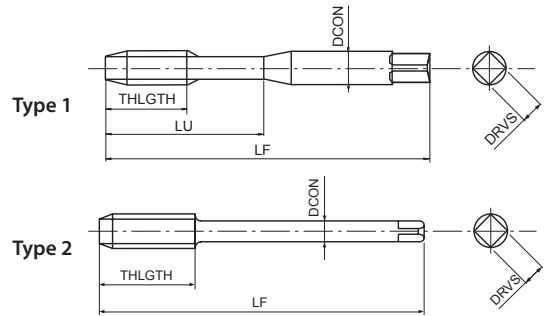
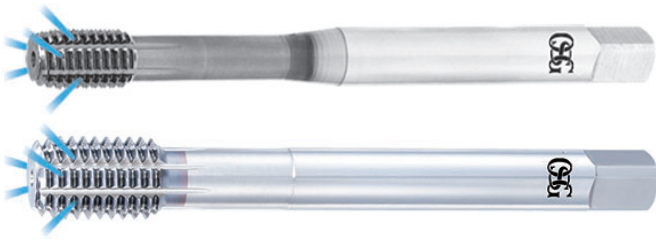

- First choice in quality and performance
- Carbide forming tap for through and blind holes
- Multilayer TiCN coating
- For general steels, stainless steels, aluminium
- With side through coolant

P	P	P	P	M	N	N	H	
C < 0,2%	0,25 < C < 0,4	C ≥ 0,45%	SCM	INOX	Al	AC, ADC	25-35 HRC	
15-40	15-40	15-30	15-30	8-20	20-50	20-40	5-20	m/min



EDP	TD	TP	LF	THLGTH	LU	DCON	DRVS	NOF	PHD	Type	DIN
48226149	5	0,8	70	-	25	6	4,9	5	4,62 ~ 4,68	1	2174
48226155	6	1	80	-	30	6	4,9	5	5,51 ~ 5,59	1	2174
48226161	8	1,25	90	-	35	8	6,2	5	7,37 ~ 7,45	1	2174
48226169	10	1,5	100	-	39	10	8	8	9,24 ~ 9,33	1	2174
48226179	12	1,75	110	17	-	9	7	8	11,10 ~ 11,20	2	2174
48226191	14	2	110	20	-	11	9	8	12,96 ~ 13,08	2	2174
48226202	16	2	110	20	-	12	9	8	14,96 ~ 15,08	2	2174

A-XPf

Threading | Forming taps | Metric Fine

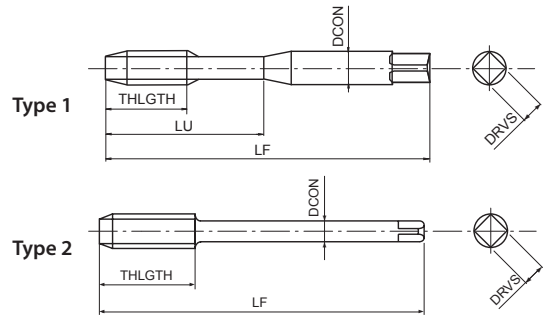

- First choice in quality and performance
- Powder metal forming tap for through and blind holes
- Multilayer VI coating
- High speed tapping in general steels, aluminium, stainless steels
- Powder metal for long tool life

Threading | Forming taps

P C < 0,2%	P 0,25 < C < 0,4	P C ≥ 0,45%	P SCM	M INOX	N Al	N AC, ADC	H 25-35 HRC	
15-40	15-40	15-30	15-30	8-20	20-50	20-40	5-20	m/min

A	MF	PM	V D > M16	VI D ≤ M16	ISO 2 6HX	C/2,5			DIN 2174	DIN 2174
----------	-----------	-----------	---------------------	----------------------	------------------	--------------	--	--	-----------------	-----------------

EDP	TD	TP	LF	THLGTH	LU	DCON	DRVS	NOF	PHD	Type	DIN
48133145	4	0,5	63	8	21	4,5	3,4	5	3,77 ~ 3,82	1	2174
48133151	5	0,5	70	8	25	6	4,9	6	4,77 ~ 4,82	1	2174
48133157	6	0,5	80	8	30	6	4,9	6	5,65 ~ 5,71	1	2174
48133156	6	0,75	80	8	30	6	4,9	6	5,79 ~ 5,83	1	2174
48133160	7	0,75	80	8	30	7	5,5	6	6,65 ~ 6,71	1	2174
48133164	8	0,5	80	10	-	6	4,9	6	7,65 ~ 7,71	2	2174
48133163	8	0,75	80	10	-	6	4,9	6	7,79 ~ 7,83	2	2174
48133162	8	1	90	10	-	6	4,9	6	7,51 ~ 7,59	2	2174
48133171	10	1	90	12	-	7	5,5	8	9,51 ~ 9,59	2	2174
48133170	10	1,25	100	12	-	7	5,5	8	9,37 ~ 9,45	2	2174
48133182	12	1	100	15	-	9	7	9	11,52 ~ 11,60	2	2174
48133181	12	1,25	100	15	-	9	7	9	11,39 ~ 11,46	2	2174
48133180	12	1,5	100	15	-	9	7	9	11,25 ~ 11,34	2	2174
48133194	14	1	100	15	-	11	9	9	13,52 ~ 13,60	2	2174
48133193	14	1,25	100	12	-	11	9	9	13,39 ~ 13,46	2	2174
48133192	14	1,5	100	15	-	11	9	9	13,25 ~ 13,34	2	2174
48133204	16	1	100	15	-	12	9	9	15,52 ~ 15,60	2	2174
48133203	16	1,5	100	15	-	12	9	9	15,25 ~ 15,34	2	2174
48133218	18	1	110	15	-	14	11	8	17,52 ~ 17,60	2	2174
48133216	18	1,5	110	15	-	14	11	8	17,25 ~ 17,34	2	2174
48133232	20	1	125	15	-	16	12	8	19,52 ~ 19,60	2	2174
48133230	20	1,5	125	15	-	16	12	8	19,25 ~ 19,34	2	2174
48133240	22	1,5	125	15	-	18	14,5	8	21,25 ~ 21,34	2	2174
48133250	24	1,5	140	15	-	18	14,5	8	23,25 ~ 23,34	2	2174



Metric Fine

A-XP F 6GX NEW

Threading | Forming taps | Metric Fine

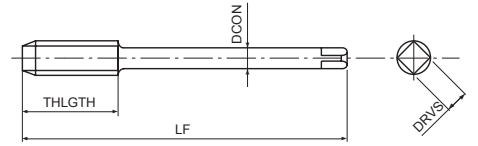

- First choice in quality and performance
- Powder metal forming tap for through and blind holes
- Multilayer VI coating
- High speed tapping in general steels, aluminium, stainless steels
- For 6G internal thread tolerance

Threading | Forming taps

P C < 0,2%	P 0,25 < C < 0,4	P C ≥ 0,45%	P SCM	M INOX	N Al	N AC, ADC	H 25-35 HRC		
15-40	15-40	15-30	15-30	8-20	20-50	20-40	5-20	m/min	

A	MF	PM	VI	ISO 3 6GX	C/2,5			DIN 2174
----------	-----------	-----------	-----------	----------------------	-------	--	--	-----------------

EDP	TD	TP	Oversize	LF	THLGTH	DCON	DRVS	NOF	PHD	DIN
48434162	8	1	0,026	90	10	6	4,9	6	7,55 ~ 7,62	2174
48434171	10	1	0,026	90	12	7	5,5	8	9,54 ~ 9,62	2174
48434180	12	1,5	0,032	100	15	9	7	9	11,27 ~ 11,36	2174
48434181	12	1,25	0,028	100	15	9	7	9	11,41 ~ 11,49	2174
48434182	12	1	0,026	100	15	9	7	9	11,55 ~ 11,63	2174
48434192	14	1,5	0,032	100	15	11	9	9	13,27 ~ 13,36	2174
48434203	16	1,5	0,032	100	15	12	9	9	15,27 ~ 15,36	2174
48434216	18	1,5	0,032	110	15	14	11	9	17,27 ~ 17,36	2174
48434230	20	1,5	0,032	125	15	16	12	9	19,27 ~ 19,36	2174

Metric Fine

A-XPF FORM E NEW

Threading | Forming taps | Metric Fine

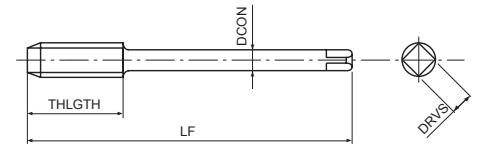

- First choice in quality and performance
- Powder metal forming tap for through and blind holes
- Multilayer VI coating
- High speed tapping in general steels, aluminium, stainless steels
- Form E chamfer

P ●	P ●	P ●	P ●	M ●	N ●	N ●	H ●	
C < 0,2%	0,25 < C < 0,4	C ≥ 0,45%	SCM	INOX	Al	AC, ADC	25-35 HRC	
15-40	15-40	15-30	15-30	8-20	20-50	20-40	5-20	m/min

A	MF	PM	VI	ISO 2 6HX	E/1,5			DIN 2174
----------	-----------	-----------	-----------	------------------	--------------	--	--	-----------------

EDP	TD	TP	LF	THLGTH	DCON	DRVS	NOF	PHD	DIN
48436171	10	1	90	12	7	5,5	8	9,51 ~ 9,59	2174
48436180	12	1,5	100	15	9	7	9	11,25 ~ 11,34	2174
48436192	14	1,5	100	15	11	9	9	13,25 ~ 13,34	2174
48436203	16	1,5	100	15	12	9	9	15,25 ~ 15,34	2174

Threading | Forming taps



Metric Fine

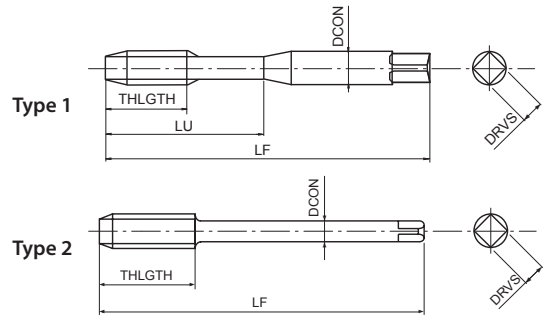

- First choice in quality and performance
- HSE forming tap for through and blind holes
- Multilayer TiCN coating
- For general steels, stainless steels, aluminium

Threading | Forming taps

P C < 0,2%	P 0,25 < C < 0,4	P C ≥ 0,45%	P SCM	M INOX	N Al	N AC, ADC	H 25-35 HRC		m/min
15-40	15-40	15-30	15-30	8-20	20-50	20-40	5-20		

A	MF	HSS-Co	V	ISO 2 6HX	C/2,5	DIN 2174	DIN 2174
----------	-----------	---------------	----------	------------------	--------------	-----------------	-----------------

EDP	TD	TP	LF	THLGTH	LU	DCON	DRVS	NOF	PHD	Type	DIN
48030145	4	0,5	63	8	21	4,5	3,4	4	3,77 ~ 3,82	1	2174
48030151	5	0,5	70	8	25	6	4,9	5	4,77 ~ 4,82	1	2174
48030157	6	0,5	80	8	30	6	4,9	5	5,79 ~ 5,83	1	2174
48030156	6	0,75	80	8	30	6	4,9	5	5,65 ~ 5,71	1	2174
48030160	7	0,75	80	8	30	7	5,5	5	6,65 ~ 6,71	1	2174
48030164	8	0,5	80	10	-	6	4,9	5	7,79 ~ 7,83	2	2174
48030163	8	0,75	80	10	-	6	4,9	5	7,65 ~ 7,71	2	2174
48030162	8	1	90	10	-	6	4,9	5	7,51 ~ 7,59	2	2174
48030171	10	1	90	12	-	7	5,5	8	9,51 ~ 9,59	2	2174
48030170	10	1,25	100	12	-	7	5,5	8	9,37 ~ 9,45	2	2174
48030182	12	1	100	15	-	9	7	8	11,52 ~ 11,60	2	2174
48030181	12	1,25	100	15	-	9	7	8	11,39 ~ 11,46	2	2174
48030180	12	1,5	100	15	-	9	7	8	11,25 ~ 11,34	2	2174
48030194	14	1	100	15	-	11	9	8	13,52 ~ 13,60	2	2174
48030193	14	1,25	100	15	-	11	9	8	13,39 ~ 13,46	2	2174
48030192	14	1,5	100	15	-	11	9	8	13,25 ~ 13,34	2	2174
48030204	16	1	100	15	-	12	9	8	15,52 ~ 15,60	2	2174
48030203	16	1,5	100	15	-	12	9	8	15,25 ~ 15,34	2	2174
48030218	18	1	110	15	-	14	11	8	17,52 ~ 17,60	2	2174
48030216	18	1,5	110	15	-	14	11	8	17,25 ~ 17,34	2	2174
48030232	20	1	125	15	-	16	12	8	19,52 ~ 19,60	2	2174
48030230	20	1,5	125	15	-	16	12	8	19,25 ~ 19,34	2	2174
48030240	22	1,5	125	15	-	18	14,5	8	21,25 ~ 21,34	2	2174
48030250	24	1,5	140	15	-	18	14,5	8	23,25 ~ 23,34	2	2174

Metric Fine

S-OIL-XPF

Threading | Forming taps | Metric Fine

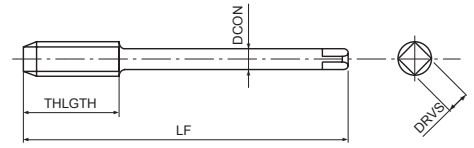

- First choice in quality and performance
- HSE forming tap for through and blind holes
- Multilayer TiCN coating
- For general steels, stainless steels, aluminium
- Side through coolant

P	P	P	P	M	N	N	H	
C < 0,2%	0,25 < C < 0,4	C ≥ 0,45%	SCM	INOX	Al	AC, ADC	25-35 HRC	m/min
15-40	15-40	15-30	15-30	8-20	20-50	20-40	5-20	

A	MF	HSS-Co	V	ISO 2 6HX					DIN 2174
----------	-----------	---------------	----------	------------------	--	--	--	--	-----------------

EDP	TD	TP	LF	THLGTH	DCON	DRVS	NOF	PHD	DIN
48042162	8	1	90	10	6	4,9	5	7,51 ~ 7,59	2174
48042171	10	1	90	12	7	5,5	8	9,51 ~ 9,59	2174
48042170	10	1,25	100	12	7	5,5	8	9,37 ~ 9,45	2174
48042182	12	1	100	15	9	7	8	11,52 ~ 11,60	2174
48042181	12	1,25	100	15	9	7	8	11,39 ~ 11,46	2174
48042180	12	1,5	100	15	9	7	8	11,25 ~ 11,34	2174
48042194	14	1	100	15	11	9	8	13,52 ~ 13,60	2174
48042193	14	1,25	100	12	11	9	8	13,39 ~ 13,46	2174
48042192	14	1,5	100	15	11	9	8	13,25 ~ 13,34	2174
48042204	16	1	100	15	12	9	8	15,52 ~ 15,60	2174
48042203	16	1,5	100	15	12	9	8	15,25 ~ 15,34	2174
48042218	18	1	110	15	14	11	8	17,52 ~ 17,60	2174
48042216	18	1,5	110	15	14	11	8	17,25 ~ 17,34	2174
48042232	20	1	125	15	16	12	8	19,52 ~ 19,60	2174
48071230	20	1,5	125	15	16	12	8	19,25 ~ 19,34	2174
48071240	22	1,5	125	15	18	14,5	8	21,25 ~ 21,34	2174
48071250	24	1,5	140	15	18	14,5	8	23,25 ~ 23,34	2174

Threading | Forming taps
Metric Fine



S-XPF 6GX

Threading | Forming taps | Metric Fine

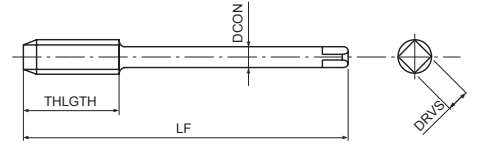

- First choice in quality and performance
- HSE forming tap for through and blind holes
- Multilayer TiCN coating
- For general steels, stainless steels, aluminium
- For 6G internal thread tolerance

Threading | Forming taps

P C < 0,2%	P 0,25 < C < 0,4	P C ≥ 0,45%	P SCM	M INOX	N Al	N AC, ADC	H 25-35 HRC		m/min
15-40	15-40	15-30	15-30	8-20	20-50	20-40	5-20		
A	MF	HSS-Co	V	ISO 3 6GX	C/2,5				DIN 2174

EDP	TD	TP	Oversize	LF	THLGTH	DCON	DRVS	NOF	PHD	DIN
48086162	8	1	0,0260	90	12	6	4,9	5	7,55 ~ 7,62	2174
48086171	10	1	0,0260	90	12	7	5,5	8	9,54 ~ 9,62	2174
48086170	10	1,25	0,0280	100	12	7	5,5	8	9,40 ~ 9,47	2174
48086182	12	1	0,0260	100	15	9	7	8	11,55 ~ 11,63	2174
48086181	12	1,25	0,0280	100	15	9	7	8	11,41 ~ 11,49	2174
48086180	12	1,5	0,0320	100	15	9	7	8	11,27 ~ 11,36	2174
48086193	14	1,25	0,0280	100	12	11	9	8	13,41 ~ 13,49	2174
48086192	14	1,5	0,0320	100	15	11	9	8	13,27 ~ 13,36	2174
48086203	16	1,5	0,0320	100	15	12	9	8	15,27 ~ 15,36	2174
48086216	18	1,5	0,0320	110	15	14	11	8	17,27 ~ 17,36	2174
48086230	20	1,5	0,0320	125	15	16	12	8	19,27 ~ 19,36	2174
48086240	22	1,5	0,0320	125	15	18	14,5	8	21,27 ~ 21,36	2174
48086250	24	1,5	0,0320	140	15	18	14,5	8	23,29 ~ 23,38	2174

Metric Fine

S-OIL-XPF 6GX

Threading | Forming taps | Metric Fine

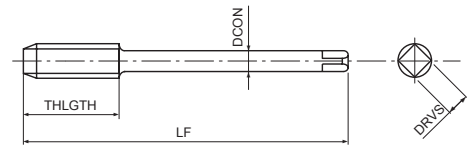

- First choice in quality and performance
- HSE forming tap for through and blind holes
- Multilayer TiCN coating
- For general steels, stainless steels, aluminium
- For 6G internal thread tolerance, side through coolant

P C < 0,2%	P 0,25 < C < 0,4	P C ≥ 0,45%	P SCM	M INOX	N Al	N AC, ADC	H 25-35 HRC	
15-40	15-40	15-30	15-30	8-20	20-50	20-40	5-20	m/min

A	MF	HSS-Co	V	ISO 3 6GX	C/2,5					DIN 2174
----------	-----------	---------------	----------	------------------	--------------	--	--	--	--	-----------------

EDP	TD	TP	Override	LF	THLGTH	DCON	DRVS	NOF	PHD	DIN
48293162	8	1	0,0260	90	10	6	4,9	5	7,54 ~ 7,62	2174
48293171	10	1	0,0260	90	10	7	5,5	8	9,54 ~ 9,62	2174
48293170	10	1,25	0,0280	100	12	7	5,5	8	9,40 ~ 9,47	2174
48293182	12	1	0,0260	100	12	9	7	8	11,55 ~ 11,63	2174
48293181	12	1,25	0,0280	100	12	9	7	8	11,41 ~ 11,49	2174
48293180	12	1,5	0,0320	100	15	9	7	8	11,27 ~ 11,36	2174
48293193	14	1,25	0,0280	100	16	11	9	8	13,41 ~ 13,49	2174
48293192	14	1,5	0,0320	100	16	11	9	8	13,27 ~ 13,36	2174
48293203	16	1,5	0,0320	100	15	12	9	8	15,27 ~ 15,36	2174
48293216	18	1,5	0,0320	110	15	14	11	8	17,27 ~ 17,36	2174
48293230	20	1,5	0,0320	125	15	16	12	8	19,27 ~ 19,36	2174
48293240	22	1,5	0,0320	125	15	18	14,5	8	21,27 ~ 21,36	2174
48293250	24	1,5	0,0320	140	15	18	14,5	8	23,29 ~ 23,38	2174



S-XPF FORM D

Threading | Forming taps | Metric Fine

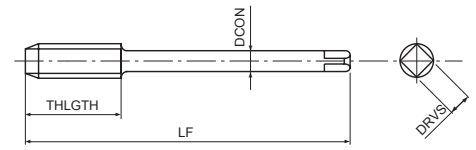

- First choice in quality and performance
- HSE forming tap for through holes
- Multilayer TiCN coating
- For general steels, stainless steels, aluminium
- Chamfer Form D

C < 0,2%	0,25 < C < 0,4	C ≥ 0,45%	SCM	INOX	Al	AC, ADC	25-35 HRC	
15-40	15-40	15-30	15-30	8-20	20-50	20-40	5-20	m/min

--	--	--	--	--	--	--	--

EDP	TD	TP	LF	THLGTH	DCON	DRVS	NOF	PHD	DIN
48088162	8	1	90	10	6	4,9	5	7,51 ~ 7,59	2174
48088171	10	1	90	12	7	5,5	8	9,51 ~ 9,59	2174
48088170	10	1,25	100	12	7	5,5	8	9,37 ~ 9,45	2174
48088182	12	1	100	15	9	7	8	11,52 ~ 11,60	2174
48088181	12	1,25	100	15	9	7	8	11,39 ~ 11,46	2174
48088180	12	1,5	100	15	9	7	8	11,25 ~ 11,34	2174
48088192	14	1,5	100	15	11	9	8	13,25 ~ 13,34	2174
48088203	16	1,5	100	15	12	9	8	15,25 ~ 15,34	2174
48088216	18	1,5	110	15	14	11	8	17,25 ~ 17,34	2174
48088230	20	1,5	125	15	16	12	8	19,25 ~ 19,34	2174

Threading | Forming taps

Metric Fine

S-OIL-XPFORM E

Threading | Forming taps | Metric Fine

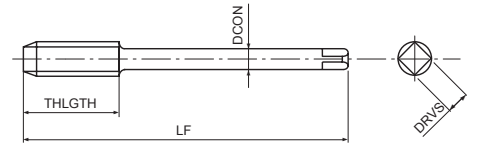

- First choice in quality and performance
- HSSE forming tap for blind holes
- Multilayer TiCN coating
- For general steels, stainless steels, aluminium
- Centre through coolant, chamfer Form E

Threading | Forming taps

P	P	P	P	M	N	N	H	
C < 0,2%	0,25 < C < 0,4	C ≥ 0,45%	SCM	INOX	Al	AC, ADC	25-35 HRC	
15-40	15-40	15-30	15-30	8-20	20-50	20-40	5-20	m/min
A	MF	HSS-Co	V	ISO 2 6HX				DIN 2174

Metric Fine

EDP	TD	TP	LF	THLGTH	DCON	DRVS	NOF	PHD	DIN
48294162	8	1	90	10	6	4,9	5	7,51 ~ 7,59	2174
48294171	10	1	90	10	7	5,5	8	9,51 ~ 9,59	2174
48294170	10	1,25	100	12	7	5,5	8	9,37 ~ 9,45	2174
48294182	12	1	100	12	9	7	8	11,52 ~ 11,60	2174
48294181	12	1,25	100	12	9	7	8	11,39 ~ 11,46	2174
48294180	12	1,5	100	15	9	7	8	11,25 ~ 11,34	2174
48294193	14	1,25	100	16	11	9	8	13,39 ~ 13,46	2174
48294192	14	1,5	100	16	11	9	8	13,25 ~ 13,34	2174
48294203	16	1,5	100	15	12	9	8	15,25 ~ 15,34	2174
48294216	18	1,5	110	15	14	11	8	17,25 ~ 17,34	2174
48294230	20	1,5	125	15	16	12	8	19,25 ~ 19,34	2174
48294240	22	1,5	125	15	18	14,5	8	21,25 ~ 21,34	2174
48294250	24	1,5	140	15	18	14,5	8	23,25 ~ 23,34	2174

S-OIL-LT-XPF

Threading | Forming taps | Metric Fine

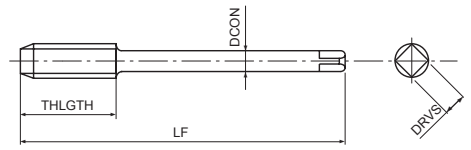

- First choice in quality and performance
- HSE forming tap for through and blind holes
- Multilayer TiCN coating
- For general steels, stainless steels, aluminium
- With long shank for long reach threading, side through coolant

P C < 0,2%	P 0,25 < C < 0,4	P C ≥ 0,45%	P SCM	M INOX	N Al	N AC, ADC	H 25-35 HRC	
15-40	15-40	15-30	15-30	8-20	20-50	20-40	5-20	m/min

A	MF	HSS-Co	V	ISO 2 6HX	C/2,5				DIN 2174
----------	-----------	---------------	----------	----------------------	--------------	--	--	--	-----------------

EDP	TD	TP	LF	THLGTH	DCON	DRVS	NOF	PHD	DIN
48295162	8	1	180	10	6	4,9	5	7,51 ~ 7,59	2174
48295171	10	1	200	12	7	5,5	8	9,51 ~ 9,59	2174
48295170	10	1,25	200	12	7	5,5	8	9,37 ~ 9,45	2174
48295182	12	1	200	15	9	7	8	11,52 ~ 11,60	2174
48295181	12	1,25	200	15	9	7	8	11,39 ~ 11,46	2174
48295180	12	1,5	200	15	9	7	8	11,25 ~ 11,34	2174
48295193	14	1,25	220	15	11	9	8	13,39 ~ 13,46	2174
48295192	14	1,5	220	15	11	9	8	13,25 ~ 13,34	2174

S-XPF-GL

Threading | Forming taps | Metric Fine

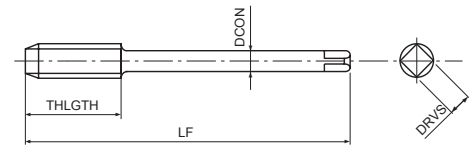

- First choice in quality and performance
- HSE forming tap for through and blind holes
- Multilayer TiCN coating
- For general steels, stainless steels, aluminium
- Without oil grooves for higher rigidity

Threading | Forming taps

P C < 0,2%	P 0,25 < C < 0,4	P C ≥ 0,45%	P SCM	M INOX	N Al	N AC, ADC	H 25-35 HRC		m/min
15-40	15-40	15-30	15-30	8-20	20-50	20-40	5-20		

A	MF	HSS-Co	V	ISO 2 6HX	C/2,5				DIN 2174
----------	-----------	---------------	----------	------------------	--------------	--	--	--	-----------------

Metric Fine

EDP	TD	TP	LF	THLGTH	DCON	DRVS	NOF	PHD	DIN
48296162	8	1	90	10	6	4,9	0	7,51 ~ 7,59	2174
48296171	10	1	90	10	7	5,5	0	9,51 ~ 9,59	2174
48296170	10	1,25	100	12	7	5,5	0	9,37 ~ 9,45	2174
48296182	12	1	100	12	9	7	0	11,52 ~ 11,60	2174
48296181	12	1,25	100	12	9	7	0	11,39 ~ 11,46	2174
48296180	12	1,5	100	15	9	7	0	11,25 ~ 11,34	2174
48296193	14	1,25	100	16	11	9	0	13,39 ~ 13,46	2174
48296192	14	1,5	100	16	11	9	0	13,25 ~ 13,34	2174
48296203	16	1,5	100	15	12	9	0	15,25 ~ 15,34	2174
48296216	18	1,5	110	15	14	11	0	17,25 ~ 17,34	2174
48296230	20	1,5	125	15	16	12	0	19,25 ~ 19,34	2174
48296240	22	1,5	125	15	18	14,5	0	21,25 ~ 21,34	2174
48296250	24	1,5	140	15	18	14,5	0	23,25 ~ 23,34	2174

S-XPF-GL 6GX

Threading | Forming taps | Metric Fine

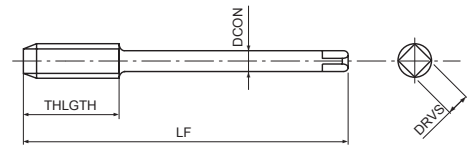

- First choice in quality and performance
- HSE forming tap for through and blind holes
- Multilayer TiCN coating
- For general steels, stainless steels, aluminium
- Without oil grooves for higher rigidity, for 6G internal thread tolerance

P C < 0,2%	P 0,25 < C < 0,4	P C ≥ 0,45%	P SCM	M INOX	N Al	N AC, ADC	H 25-35 HRC		
15-40	15-40	15-30	15-30	8-20	20-50	20-40	5-20		m/min
A	MF	HSS-Co	V	ISO 3 6GX	C/2,5				DIN 2174

EDP	TD	TP	Override	LF	THLGTH	DCON	DRVS	NOF	PHD	DIN
48297162	8	1	0,0260	90	10	6	4,9	0	7,54 ~ 7,62	2174
48297171	10	1	0,0260	90	10	7	5,5	0	9,54 ~ 9,62	2174
48297170	10	1,25	0,0280	100	12	7	5,5	0	9,40 ~ 9,47	2174
48297182	12	1	0,0260	100	12	9	7	0	11,55 ~ 11,63	2174
48297181	12	1,25	0,0280	100	12	9	7	0	11,41 ~ 11,49	2174
48297180	12	1,5	0,0320	100	15	9	7	0	11,27 ~ 11,36	2174
48297193	14	1,25	0,0280	100	16	11	9	0	13,41 ~ 13,49	2174
48297192	14	1,5	0,0320	100	16	11	9	0	13,27 ~ 13,36	2174
48297203	16	1,5	0,0320	100	15	12	9	0	15,27 ~ 15,36	2174
48297216	18	1,5	0,0320	110	15	14	11	0	17,27 ~ 17,36	2174
48297230	20	1,5	0,0320	125	15	16	12	0	19,27 ~ 19,36	2174
48297240	22	1,5	0,0320	125	15	18	14,5	0	21,27 ~ 21,36	2174
48297250	24	1,5	0,0320	140	15	18	14,5	0	23,29 ~ 23,38	2174

Threading | Forming taps

Metric Fine



C-OIL-XPf

Threading | Forming taps | Metric Fine

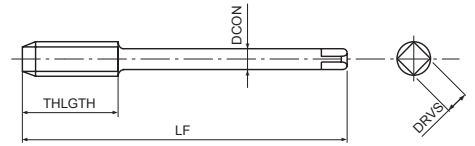

- First choice in quality and performance
- Carbide forming tap for through and blind holes
- Multilayer TiCN coating
- For general steels, stainless steels, aluminium
- Side through coolant

Threading | Forming taps

P C < 0,2%	P 0,25 < C < 0,4	P C ≥ 0,45%	P SCM	M INOX	N Al	N AC, ADC	H 25-35 HRC	
15-40	15-40	15-30	15-30	8-20	20-50	20-40	5-20	m/min
A	MF	CARBIDE	V	ISO 2 6HX	C/2,5			DIN 2174



Metric Fine

EDP	TD	TP	LF	THLGTH	DCON	DRVS	NOF	PHD	DIN
48226162	8	1	90	10	6	4,9	5	7,51 ~ 7,59	2174
48226171	10	1	90	12	7	5,5	8	9,51 ~ 9,59	2174
48226180	12	1,5	100	15	9	7	8	11,25 ~ 11,34	2174
48226192	14	1,5	100	15	11	9	8	13,25 ~ 13,34	2174
48226203	16	1,5	100	15	12	9	8	15,25 ~ 15,34	2174

Threading | Forming taps | UNC

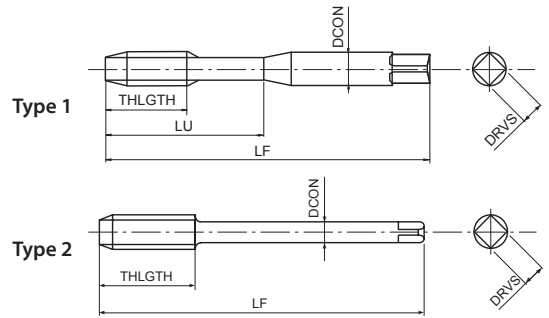

- First choice in quality and performance
- HSE forming tap for through and blind holes
- Multilayer TiCN coating
- For general steels, stainless steels, aluminium

P C < 0,2%	P 0,25 < C < 0,4	P C ≥ 0,45%	P SCM	M INOX	N Al	N AC, ADC	H 25-35 HRC	
15-40	15-40	15-30	15-30	8-20	20-50	20-40	5-20	m/min

A	UNC	HSS-Co	V	ANSI 2BX	C/2,5	DIN 2184-1	DIN 2184-1
----------	------------	---------------	----------	-----------------	--------------	-------------------	-------------------

EDP	TD	TP	LF	THLGTH	LU	DCON	DRVS	NOF	PHD	Type	DIN
48091459	5	40	56	6,3	18	3,5	2,7	4	2,86 ~ 2,93	1	2184-1
48091461	6	32	56	7,8	20	4	3	4	3,09 ~ 3,17	1	2184-1
48091464	8	32	63	7,8	21	4,5	3,4	4	3,76 ~ 3,84	1	2184-1
48091466	10	24	70	10,5	25	6	4,9	5	4,26 ~ 4,35	1	2184-1
48091471	1/4	20	80	12,5	30	7	5,5	5	5,66 ~ 5,76	1	2184-1
48091474	5/16	18	90	14	35	8	6,2	5	7,18 ~ 7,29	1	2184-1
48091479	3/8	16	100	15,9	35	9	7	8	8,66 ~ 8,78	1	2184-1
48091484	7/16	14	100	18,1	-	8	6,2	8	10,12 ~ 10,27	2	2184-1
48091489	1/2	13	110	19,5	-	9	7	8	11,62 ~ 11,78	2	2184-1
48091494	9/16	12	110	21,1	-	11	9	8	13,14 ~ 13,28	2	2184-1
48091501	5/8	11	110	23,1	-	12	9	8	14,61 ~ 14,76	2	2184-1
48091515	3/4	10	125	20,3	-	14	11	8	17,65 ~ 17,80	2	2184-1
48091526	7/8	9	140	22,6	-	18	14,5	8	20,66 ~ 20,84	2	2184-1
48091538	1	8	160	25,4	-	18	14,5	8	23,63 ~ 23,84	2	2184-1



S-OIL-XPF

Threading | Forming taps | UNC

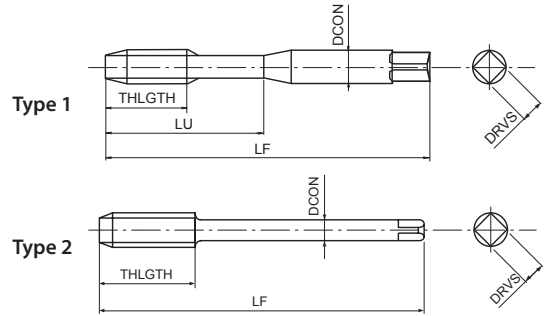
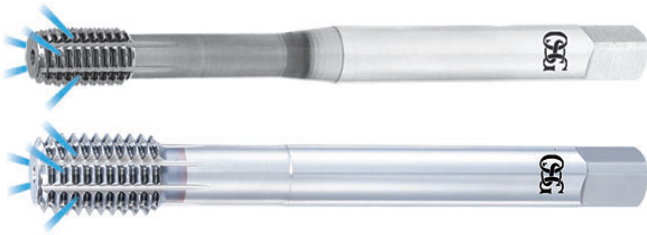

- First choice in quality and performance
- HSE forming tap for through and blind holes
- Multilayer TiCN coating
- For general steels, stainless steels, aluminium
- Side through coolant

Threading | Forming taps

UNC

P C < 0,2%	P 0,25 < C < 0,4	P C ≥ 0,45%	P SCM	M INOX	N Al	N AC, ADC	H 25-35 HRC		
15-40	15-40	15-30	15-30	8-20	20-50	20-40	5-20		m/min

A
UNC
HSS-Co
V
ANSI 2BX
C/2,5

DIN 2184-1
DIN 2184-1

EDP	TD	TP	LF	THLGTH	LU	DCON	DRVS	NOF	PHD	Type	DIN
48042471	1/4	20	80	13	30	7	5,5	5	5,66 ~ 5,76	1	2184-1
48042474	5/16	18	90	14	35	8	6,2	5	7,18 ~ 7,29	1	2184-1
48042479	3/8	16	100	11	39	10	8	8	8,66 ~ 8,78	1	2184-1
48042484	7/16	14	100	14	-	8	6,2	8	10,12 ~ 10,27	2	2184-1
48042489	1/2	13	110	20	-	9	7	8	11,62 ~ 11,78	2	2184-1
48042494	9/16	12	110	22	-	11	9	8	13,14 ~ 13,28	2	2184-1
48042501	5/8	11	110	14	-	12	9	8	14,61 ~ 14,76	2	2184-1
48042515	3/4	10	125	25,4	-	14	11	8	17,65 ~ 17,80	2	2184-1
48042526	7/8	9	140	24	-	18	14,5	8	20,66 ~ 20,84	2	2184-1
48042538	1	8	160	31,8	-	18	14,5	8	23,63 ~ 23,84	2	2184-1

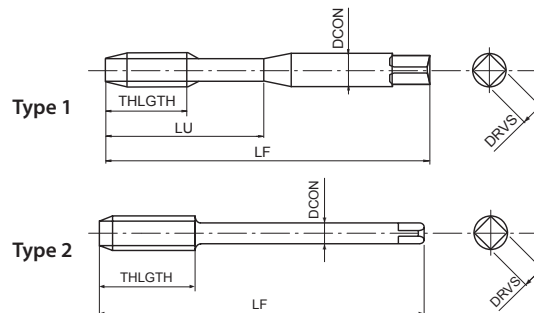

- First choice in quality and performance
- HSE forming tap for through and blind holes
- Multilayer TiCN coating
- For general steels, stainless steels, aluminium

P C < 0,2%	P 0,25 < C < 0,4	P C ≥ 0,45%	P SCM	M INOX	N Al	N AC, ADC	H 25-35 HRC		m/min
15-40	15-40	15-30	15-30	8-20	20-50	20-40	5-20		

A	UNF	HSS-Co	V	ANSI 2BX	C/2,5	DIN 2184-1	DIN 2184-1
----------	------------	---------------	----------	-----------------	--------------	-------------------	-------------------

EDP	TD	TP	LF	THLGTH	LU	DCON	DRVS	NOF	PHD	Type	DIN
48091462	6	40	56	6,3	20	4	3	4	3,19 ~ 3,26	1	2184-1
48091467	10	32	70	7,8	25	6	4,9	5	4,41 ~ 4,47	1	2184-1
48091472	1/4	28	80	9	30	7	5,5	5	5,87 ~ 5,94	1	2184-1
48091476	5/16	24	90	10,6	35	8	6,2	5	7,39 ~ 7,47	1	2184-1
48091481	3/8	24	90	10,6	35	9	7	8	8,98 ~ 9,06	1	2184-1
48091486	7/16	20	100	12,7	-	8	6,2	8	10,45 ~ 10,55	2	2184-1
48091491	1/2	20	100	12,7	-	9	7	8	12,04 ~ 12,14	2	2184-1
48091496	9/16	18	100	14,1	-	11	9	8	13,56 ~ 13,64	2	2184-1
48091504	5/8	18	100	14,1	-	12	9	8	15,15 ~ 15,23	2	2184-1
48091517	3/4	16	110	12,7	-	14	12	8	18,22 ~ 18,30	2	2184-1
48091528	7/8	14	125	14,5	-	18	14,5	8	21,27 ~ 21,38	2	2184-1
48091539	1	12	125	16,9	-	18	14,5	8	24,26 ~ 24,37	2	2184-1



S-OIL-XPF

Threading | Forming taps | UNF

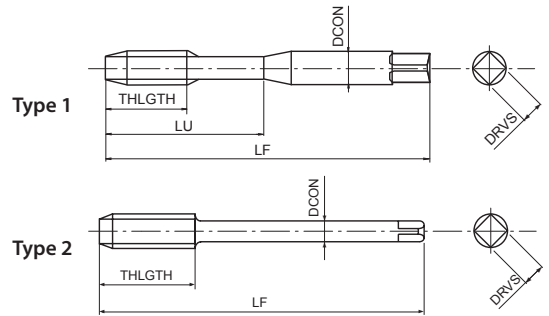
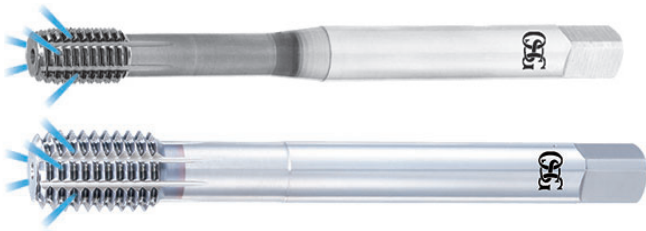

- First choice in quality and performance
- HSE forming tap for through and blind holes
- Multilayer TiCN coating
- For general steels, stainless steels, aluminium
- Side through coolant

Threading | Forming taps

P C < 0,2%	P 0,25 < C < 0,4	P C ≥ 0,45%	P SCM	M INOX	N Al	N AC, ADC	H 25-35 HRC		
15-40	15-40	15-30	15-30	8-20	20-50	20-40	5-20		m/min

A	UNF	HSS-Co	V	ANSI 2BX	C/2,5	DIN 2184-1	DIN 2184-1
----------	------------	---------------	----------	-----------------	--------------	-------------------	-------------------

EDP	TD	TP	LF	THLGTH	LU	DCON	DRVS	NOF	PHD	Type	DIN
48042472	1/4	28	80	9,1	30	7	5,5	5	5,87 ~ 5,94	1	2184-1
48042476	5/16	24	90	10,6	35	8	6,2	5	7,39 ~ 7,47	1	2184-1
48042481	3/8	24	90	10,6	35	10	8	8	8,98 ~ 9,06	1	2184-1
48042486	7/16	20	100	12,7	-	8	6,2	8	10,45 ~ 10,55	2	2184-1
48042491	1/2	20	100	12,7	-	9	7	8	12,04 ~ 12,14	2	2184-1
48042496	9/16	18	100	14,1	-	11	9	8	13,56 ~ 13,64	2	2184-1
48042504	5/8	18	100	14,1	-	12	9	8	15,15 ~ 15,23	2	2184-1
48042517	3/4	16	110	12,7	-	14	11	8	18,22 ~ 18,30	2	2184-1
48042528	7/8	14	125	14,5	-	18	14,5	8	21,27 ~ 21,38	2	2184-1
48042539	1	12	140	16,9	-	18	14,5	8	24,26 ~ 24,37	2	2184-1

A-XPFORM E NEW

Threading | Forming taps | G (BSP)

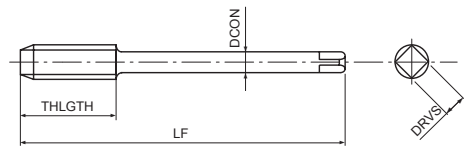

- First choice in quality and performance
- Powder metal forming tap for through and blind holes
- Multilayer VI coating
- For general steels, stainless steels, aluminium
- Form E chamfer

P C < 0,2%	P 0,25 < C < 0,4	P C ≥ 0,45%	P SCM	M INOX	N Al	N AC, ADC	H 25-35 HRC	
15-40	15-40	15-30	15-30	8-20	20-50	20-40	5-20	m/min

A	G	PM	VI	E/1,5			DIN 2189
----------	----------	-----------	-----------	--------------	--	--	-----------------

EDP	TD	TP	LF	THLGTH	DCON	DRVS	NOF	PHD	DIN
48436900	1/8	28	90	9	7	5,5	8	9,24 ~ 9,35	2189
48436000	1/4	19	100	13	11	9	9	12,41 ~ 12,62	2189
48436100	3/8	19	100	13	12	9	9	15,92 ~ 16,12	2189
48436200	1/2	14	125	18	16	12	9	19,93 ~ 20,15	2189

Threading | Forming taps



G (BSP)







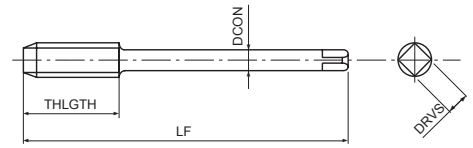

A-OIL-XPF FORM E NEW

INDEX

Threading | Forming taps | G (BSP)



- First choice in quality and performance
- Powder metal forming tap for blind holes
- Multilayer VI coating
- High speed tapping in general steels, aluminium, stainless steels
- Center through coolant, Form E chamfer

P  C < 0,2%	P  0,25 < C < 0,4	P  C ≥ 0,45%	P  SCM	M  INOX	N  Al	N  AC, ADC	H  25-35 HRC	
15-40	15-40	15-30	15-30	8-20	20-50	20-40	5-20	m/min

A	G	PM	VI	E/1,5			DIN 2189
----------	----------	-----------	-----------	-------	---	---	----------

EDP	TD	TP	LF	THLGTH	DCON	DRVS	NOF	PHD	DIN
48437900	1/8	28	90	9	7	5,5	8	9,24 ~ 9,35	2189
48437000	1/4	19	100	13	11	9	9	12,41 ~ 12,62	2189
48437100	3/8	19	100	13	12	9	9	15,92 ~ 16,12	2189
48437200	1/2	14	125	18	16	12	9	19,93 ~ 20,15	2189

S-XPF

Threading | Forming taps | G (BSP)

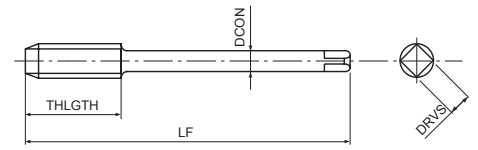

- First choice in quality and performance
- HSE forming tap for through and blind holes
- Multilayer TiCN coating
- For general steels, stainless steels, aluminium

P C < 0,2%	P 0,25 < C < 0,4	P C ≥ 0,45%	P SCM	M INOX	N Al	N AC, ADC	H 25-35 HRC		
15-40	15-40	15-30	15-30	8-20	20-50	20-40	5-20		m/min
A	G	HSS-Co	V	C/2,5				DIN 2189	

EDP	TD	TP	LF	THLGTH	DCON	DRVS	NOF	PHD	DIN
48064838	1/8	28	90	9	7	5,5	8	9,24 ~ 9,35	2189
48064839	1/4	19	100	13	11	9	8	12,41 ~ 12,62	2189
48064840	3/8	19	100	13	12	9	8	15,92 ~ 16,12	2189
48064841	1/2	14	125	18	16	12	8	19,93 ~ 20,15	2189
48064842	5/8	14	125	18	18	14,5	8	21,89 ~ 22,11	2189
48064843	3/4	14	140	18	20	16	8	25,42 ~ 25,64	2189
48064844	7/8	14	150	18	22	18	8	29,18 ~ 29,40	2189
48064845	1	11	160	23	25	20	8	31,92 ~ 32,20	2189

S-OIL-XPF

Threading | Forming taps | G (BSP)

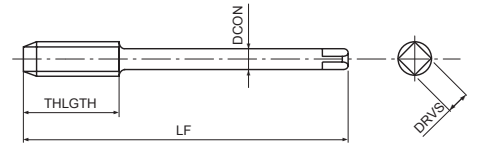
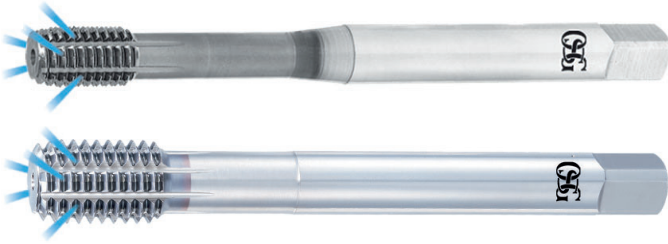

- First choice in quality and performance
- HSSE forming tap for through and blind holes
- Multilayer TiCN coating
- For general steels, stainless steels, aluminium
- Side through coolant

Threading | Forming taps

P C < 0,2%	P 0,25 < C < 0,4	P C ≥ 0,45%	P SCM	M INOX	N Al	N AC, ADC	H 25-35 HRC		m/min
15-40	15-40	15-30	15-30	8-20	20-50	20-40	5-20		
A	G	HSS-Co	V	C/2,5					DIN 2189

EDP	TD	TP	LF	THLGTH	DCON	DRVS	NOF	PHD	DIN
48042839	1/4	19	100	13	11	9	8	12,41 ~ 12,62	2189
48042840	3/8	19	100	13	12	9	8	15,92 ~ 16,12	2189
48042841	1/2	14	125	18	16	12	8	19,93 ~ 20,15	2189
48042842	5/8	14	125	18	18	14,5	8	21,89 ~ 22,11	2189
48042843	3/4	14	140	18	20	16	8	25,42 ~ 25,64	2189
48042844	7/8	14	150	18	22	18	8	29,18 ~ 29,40	2189
48042845	1	11	160	23	25	20	8	31,92 ~ 32,20	2189

S-XPF-GL

Threading | Forming taps | G (BSP)

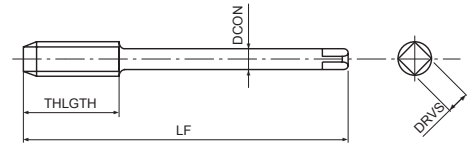

- First choice in quality and performance
- HSE forming tap for through and blind holes
- Multilayer TiCN coating
- Without oil grooves for higher rigidity

P $C < 0,2\%$	P $0,25 < C < 0,4$	P $C \geq 0,45\%$	P SCM	M INOX	N Al	N AC, ADC	H 25-35 HRC
----------------------	---------------------------	--------------------------	--------------	---------------	-------------	------------------	--------------------

A	G	HSS-Co	V	C/2,5			DIN 2189
----------	----------	---------------	----------	-------	--	--	----------

EDP	TD	TP	LF	THLGTH	DCON	DRVS	NOF	PHD	DIN
48296838	1/8	28	90	9	7	5,5	0	9,24 ~ 9,35	2189
48296839	1/4	19	100	13	11	9	0	12,41 ~ 12,62	2189
48296840	3/8	19	100	13	12	9	0	15,92 ~ 16,12	2189
48296841	1/2	14	125	18	16	12	0	19,93 ~ 20,15	2189
48296842	5/8	14	125	18	18	14,5	0	21,89 ~ 22,11	2189
48296843	3/4	14	140	18	20	16	0	25,42 ~ 25,64	2189
48296844	7/8	14	150	18	22	18	0	29,18 ~ 29,40	2189
48296845	1	11	160	23	25	20	0	31,92 ~ 32,20	2189





shaping your dreams

OSG EUROPE LOGISTICS

Avenue Lavoisier 1
B-1300 Z.I. Wavre - Nord - Belgium
Tel: +32 10 23 05 07
info@osgeurope.com

OSG POLAND Sp. z o.o.

Spółdzielcza 57
05-074 Halinów - Poland
Tel: +22 760 82 71
osg@osg-poland.com

OSG ROMANIA SRL

25C, Bucuresti-Magurele Street (Sector 5)
051431 Bucuresti - România
Tel: +40 21 322 07 47
info@osgromania.ro

OSG BELUX

Avenue Lavoisier 1
B-1300 Z.I. Wavre - Nord - Belgium
Tel: +32 10 23 05 11
info@osg-belgium.com

OSG GERMANY

Karl-Ehmann-Str. 25
D - 73037 Göppingen - Germany
Tel: +49 7161 6064 - 0
Fax: +49 7161 6064 - 444
info@osg-germany.de

AUSTRIA

Branch office of OSG GERMANY
Messestraße 11
A-6850 Dornbirn
Tel: +49 7161 6064-0
info@osg-germany.de

OSG FRANCE

Parc Icade, Paris Nord 2
Immeuble "Le Rimbaud"
22 Avenue des Nations
CS66191 - 93420 Villepinte - France
Tel: +33 1 49 90 10 10
sales@osg-france.com

OSG SCANDINAVIA

(For Scandinavian countries)
Langebjergvaenget 16
4000 Roskilde - Denmark
Tel: +45 46 75 65 55
osg@osg-scandinavia.com

OSG ITALIA

Via Ferrero, 65 A/B3
I - 10098 Rivoli - Italy
Tel: +39 0117705211
info@osg-italia.it

OSG NETHERLANDS

Bedrijfsweg 5 - 3481 MG Harmelen
Tel: +31 348 44 2764
info@osg-nl.com

SWEDEN

Branch office of OSG SCANDINAVIA
Singelgatan 7
212 28 Malmö - Sweden
Tel: +46 40 41 22 55
osg@osg-scandinavia.com

Vischer & Bolli AG

Machining and Workholding
Im Schossacher 17
CH-8600 Dübendorf
T +41 44 802 15 15
info@vb-tools.com

OSG UK

Kelsey Close, Attleborough Fields Ind Est,
CV11 6RS, Nuneaton, United Kingdom.
Tel: +44 1827 720 013
uk_sales@osg-uk.com

OSG IBERICA

Bekolarra 4
E - 01010 Vitoria-Gasteiz - Spain
Tel: +34 945 242 400
osg.iberica@osg-ib.com

CZECH, SLOVAKIA, HUNGARY

OSG Europe Logistics S.A.
Slovakia organizacna zlozka
Racianská 22/A, SK-83102 Bratislava
Slovakia
Tel. +421 24 32 91 295
Orders-osgsvk@osgeurope.com

OSG TURKEY

Rami Kışla Cad.No:56 Eyüp
Istanbul 34056 - Turkey
Tel+90 212 565 24 00
Fax: +90 212 565 44 00
info@osg-turkey.com

OSG EUROPE LOGISTICS S.A.

04/2025 - All rights reserved. © OSG Europe 2025

The contents of this catalogue are provided to you for viewing only. They are not intended for reproduction either in part or in whole in this or other medium. They cannot be copied, used to create derivation work or used for any reason, by means without the express, written permission of the copyright owner. If prices are stated, they are netto unit-prices and any eventual tax(es) have to be added. The company is not responsible for any printing error in technical, price and/or any other data.

Tool specifications subject to change without notice.

www.osgeurope.com

